

codex

BEARINGS
Catalogue

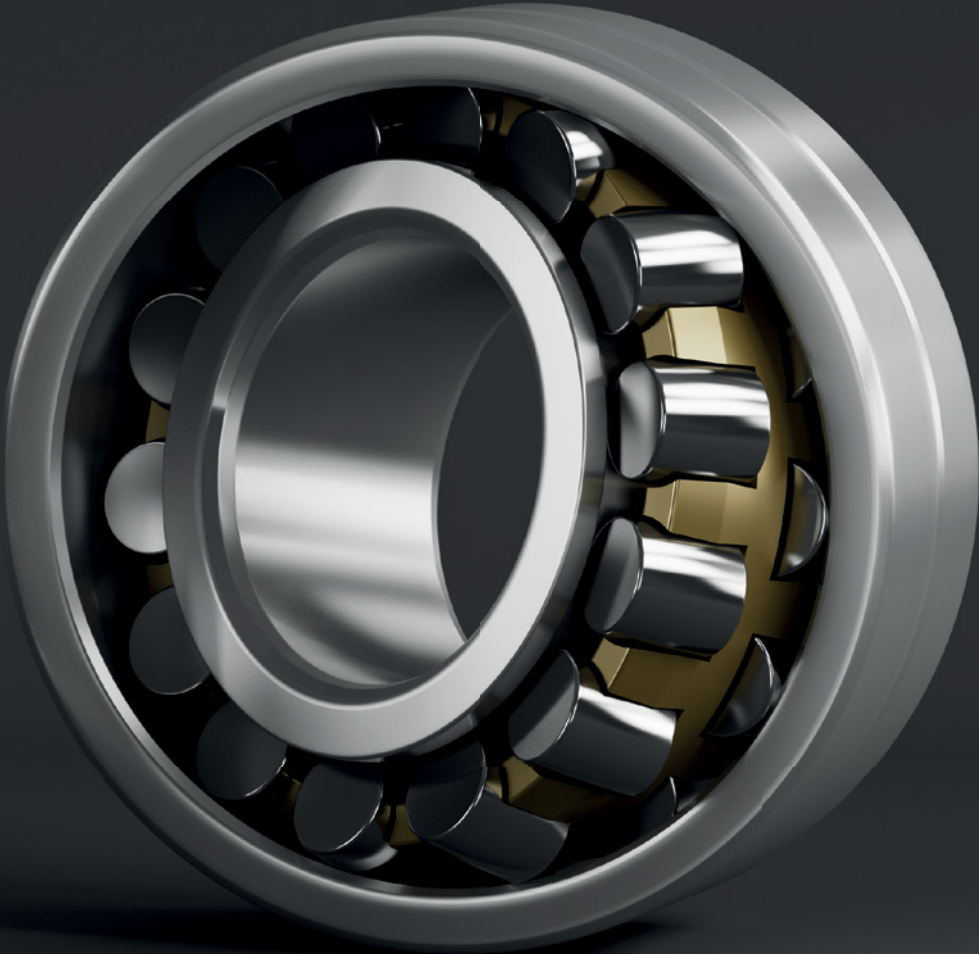

Content

ABOUT CODEX	4
QUALITY	6
GENERAL DATA	11
Bearings	12
Bearing Designation	22
Materials	28
Bearing manufacturing tolerances	32
Bearing Cages	50
Assembly and disassembly of bearings	56
Bearing maintenance	60
CODEX PRODUCT RANGE	65
Deep groove ball bearings	66
Angular contact Ball Bearings	76
Self-aligning ball bearings	82
Tapered roller bearings	86
Cylindrical roller bearings	94
Spherical roller bearings	102
Axial thrust bearings	108
Spherical plain bearings and rod ends	112
Solutions for agriculture	120
Codex Bearing Units	126
Codex SNL Plummer housings	134
Bearing accessories	140

About Codex

Codex is a trusted and reliable bearing and driving elements supplier that was established in 1993 in a small Slovenian town called Murska Sobota. Today, our company has grown into an international global network with more than 400 distributors and 160 OEM customers in more than 40 countries around the world.

We specialise in industrial bearings and supply our own brands in three distinct quality levels, Codex, Codex Extreme and Codex MSC. Decades of experience and research means that all Codex products have an impressive price-performance ratio. The constant pursuit of the best value for money for our customers is the very essence of our company.

Our success relies on our growing team of specialists at Codex, including our sales and purchase team, our customer support and quality assurance experts, experienced logistics & warehouse operatives, IT, marketing, accounting and management specialists, all located at our modern Codex headquarters. In addition, we have an international team of key account managers from all over the world as well as our colleagues in Shanghai, a team of laboratory inspection professionals.

The Central European location of our company means that we are strategically positioned to arrange the dispatch of our orders across the whole of Europe. Our logistics centre also has gained AEO status (Authorised Economic Operator status).

By utilising modern technologies and a well organised logistical system, we are able to process customer orders precisely and in the shortest possible time all the way through from factory to the end user. A special system of product designation, storage and dispatch allows us to process your orders fast and with the minimum potential for human error, therefore helping to minimise the number of complaints. Our distribution customers can also track their orders through our exclusive B2B webstore, "Potissimus".



Quality

At Codex, we use advanced testing and measuring equipment as well as rigorous and effective quality inspection processes, providing us full traceability of our products and ensuring that every single batch of products delivered to our customers is of the highest quality standard.

We perform a wide range of test and inspection procedures related to the life cycle of our products.

Product testing and quality inspections are carried out in our laboratories in both Europe and in the East and include, but are not limited to, dimensional, material, physical and functional parameter inspections.

Our strict quality control procedures ensure that Codex products always comply with our customers' requirements and that our products comply with all relevant international standards.

3-phase inspection

Quality assurance begins with the careful selection of our partners and the initial parts approval at our **laboratory in Slovenia**. Every single production batch is inspected during the manufacturing process and externally in our independent inspection **laboratory in Shanghai** to ensure that international standards or customer-specific requirements are met. In-house laboratory inspection facilities in Europe and Shanghai allow us to be fast, flexible and agile to market and to be able to meet client demands.

In both laboratories, we follow sampling procedures according to ISO2859 and sampling schemes indexed by acceptance quality limit (AQL) for lot-by-lot inspection. Technology and measurement

approaches include waviness, roughness, roundness and form analysis, noise and vibration testing for bearings, radial and axial internal clearance and runout, dimension testing, optical inspection, hardness and other non-destructive testing and finalising with standardised report. Inspections and testing not available in-house are performed at external accredited laboratories.

Certification

The implemented and process-oriented management system defines our quality requirements according to ISO 9001:2015. Moreover, we are certified for market-specific requirements such as TSE (Türk Standardları Enstitüsü) and are a certified Authorised Economic Operator (AEO).

CODEX BRANDS & QUALITY LEVELS

Providing the best value for money for our customers was always our key objective. Therefore, we supply our bearings in three distinct quality levels, Codex Extreme, Codex and Codex MSC. Each quality level is designed to meet specific quality requirements, therefore being fully cost optimised.



Codex EXTREME

- High-quality level
- EMQ (Electric motor quality) bearings
- High revolution
- Low vibration and low noise
- High running accuracy
- Quality checked



Codex

- Standard quality level
- Suitable for all general applications
- Best price-performance
- Quality checked



Codex MSC

- Economical solution
- Ideal for less demanding applications



GENERAL DATA



Bearings

A rolling bearing is an important mechanical component that is used in various machines and industries and used almost everywhere where rotation is necessary.

Rolling bearings are required to have a long and smooth operating life, **to be small, lightweight, fast**, to operate quietly and to withstand various environments. In general, the requirements of bearing applications are increasing year on year and it is only by continuous monitoring of performance and development that market demands can be met.

Most rolling bearings consist of an inner and outer ring with a raceway, rolling elements (either balls or rollers) and a cage.

The raceway is a surface on rings or washers where rolling elements are rolling and which supports the load of the bearing. Generally, the inner ring fits on the axle or shaft and the outer ring fits in the housing.

Rolling elements are generally classified into two groups: balls and rollers. Rollers are divided into four types: cylindrical, needle, tapered and spherical.

The cage is holding the rolling elements in place to run on the raceways and ensuring separation between the elements so that they can run smoothly and freely.

BEARING TYPES AND THEIR COMPONENTS

Type	Bearing	Outer ring	Inner ring	Rolling elements	Cage
Ball bearing					
Cylindrical roller bearing					
Tapered roller bearing		 (cup)	 (cone)		
Double-row spherical roller bearing					
Needle roller bearing					
Ball thrust bearing		 (housing ring)	 (shaft ring)		
Spherical roller thrust bearing		 (housing ring)	 (shaft ring)		

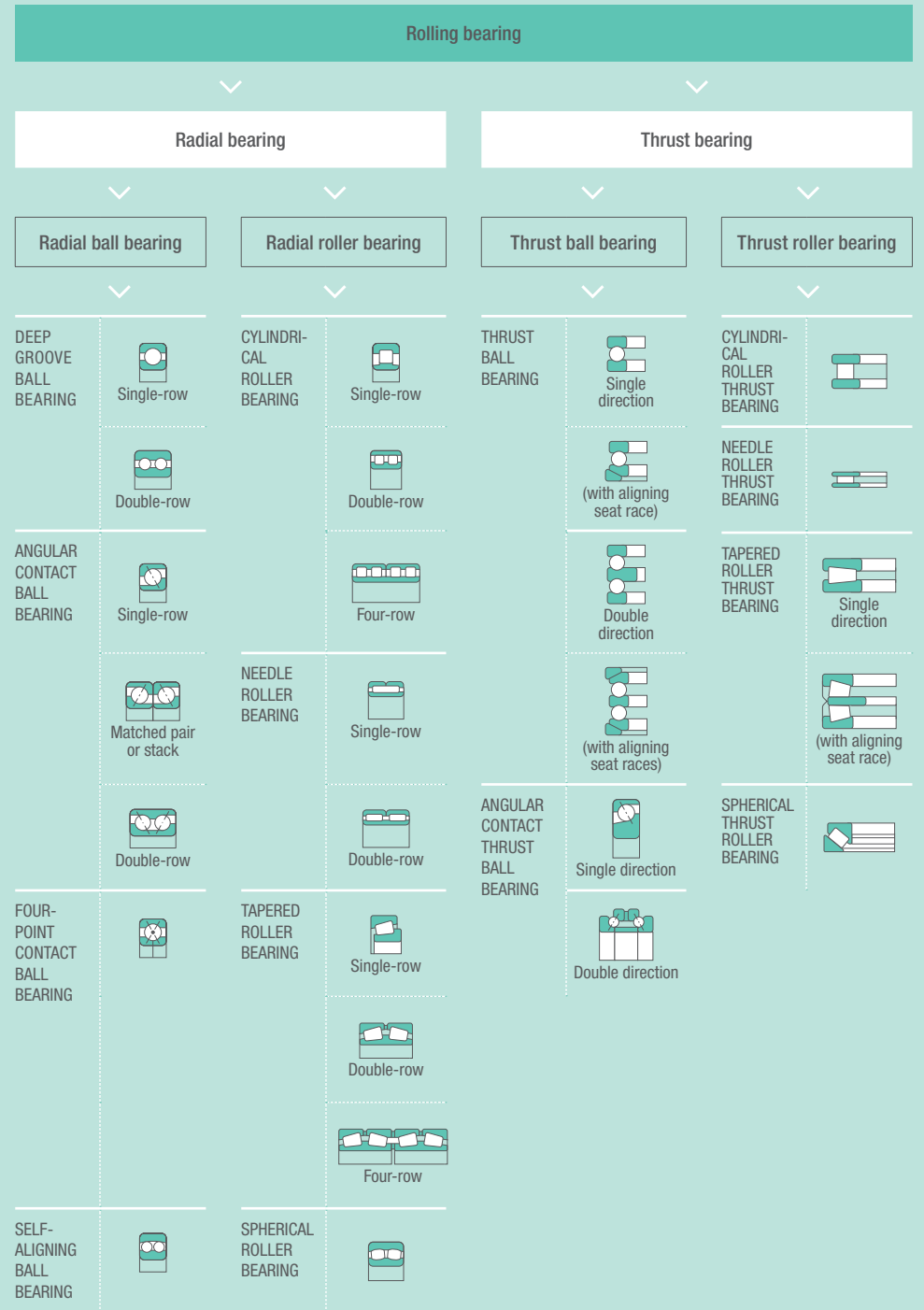

BEARING TYPES



Deep groove ball bearings

Deep groove ball bearings are the most common type of bearing and are widely used in numerous applications. Deep groove ball bearings can include shielded bearings (ZZ type) or sealed bearings (2RS type) pre-greased and ready to use. Deep groove ball bearings are also available as an **Angular contact ball bearing**, where contact point between inner ring, ball and outer ring runs at a certain angle in the radial direction. Angular contact ball bearings can support load in an axial direction but cannot be used alone because of the contact angle. They must instead be used in pairs or in combination. Angular contact ball bearings include **Double row angular contact ball bearings** for which the inner and outer rings are combined as a single unit. There are also **Four-point contact bearings** that can support an axial load in both directions by themselves. However, these bearings require caution, because problems such as excessive temperature rise and wear could occur depending on the load conditions.



Cylindrical roller bearings

Cylindrical roller bearings use rollers for rolling elements. The rollers are guided by the ribs of the inner or outer ring. The inner and outer rings can be separated to facilitate assembly, and both can be fitted tightly with a shaft or housing. If there are no ribs, either the inner or the outer ring can move freely in the axial direction.

Cylindrical roller bearings can accommodate heavy radial loads due to the line contact formed between their rolling elements (cylinder) and raceways. The most common design is a **single row cylindrical roller bearing** with cage, but they are also available as **double** or **multi row and with** different designs. These bearings are suitable for high-speed applications, as rollers are guided by either inner or outer ring ribs.



Tapered roller bearings

Tapered roller bearings are designed in such way that the tapered vertex of the raceway surfaces of the inner and outer rings and rollers converge at one point on the centreline of the bearing axis. The tapered rollers are guided by the compound force of the inner and outer raceway surfaces, which keep the rollers pressed up against the large rib on the inner ring. A large variety of these bearings are available, including **single, double** and **four row** arrangements. These bearings' design enables them to handle high radial and axial loads.



Spherical roller bearings

Spherical roller bearings consist of an outer ring having a continuous spherical raceway and **two rows** of “barrel-shaped” rolling elements guided by an inner ring with two raceways. The bearing has self-aligning properties and is suited for use where misalignment between the inner and outer rings occurs from housing installation error or shaft bending. Spherical roller bearings have a large capacity for radial loads, axial loads in either direction and combined loads. They are also suited for applications where vibration and shock loads are involved. Bearings are available in several types that differ in the structure of inner ring, cage and cage guidance.

BEARING TYPES



Needle roller bearings

A needle roller bearing is a bearing that uses small cylindrical rollers as rolling elements. These rollers are used to reduce the friction of a rotating surface compared with ball bearings; needle roller bearings have a larger surface area that is in contact with the bearing raceway journals. The typical structure of a needle roller bearing comprises of an inner race (or sometimes just a shaft), a needle cage which orientates and contains the needle rollers, the needle rollers themselves and an outer raceway. Due to the large number of rolling elements, needle roller bearings have high rigidity and are ideally suited to oscillating motion. There are many different designs of needle roller bearings, including with cage, solid type needle roller bearing and drawn cup needle roller bearing.



Thrust bearings

Thrust bearings are designed primarily to support axial loads at contact angles between 30° and 90°. Similar to radial bearings, thrust bearing designs may incorporate balls or rollers as rolling elements. With thrust bearings, it is necessary to supply an axial preload in order to prevent slipping between the bearing's rolling elements and raceways. Bearings are available in several designs, such as **thrust ball bearings, thrust spherical roller bearings, thrust cylindrical roller bearings and thrust tapered roller bearings** with different cage designs.

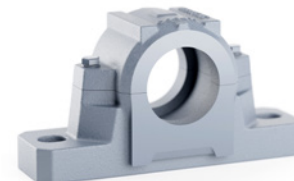

Bearing housings–plummer blocks

The plummer block, which is an assembly comprising of a self-aligning ball bearing or spherical roller bearing placed in a bearing housing of various shapes, has a large load capacity and is easy to handle, therefore it is widely used in general industrial machinery such as conveyors. Plummer block housings offer:

1. Low weight to strength ratio
2. Ease of mounting and dismounting
3. High strength and rigidity

The housings can incorporate rubber seals, felt seals or labyrinth seals depending on the application. Grease and oil are both available for lubrication.



Special solutions

The Codex product portfolio also consists of special solution bearings and units dedicated to specific industries and applications. One of these special solutions is our family of **Life-time greased Agricultural Bearing Solutions**, all performing with high load capacity and impeccable wear resistance. With low friction characteristics and one-piece housing, they provide the user with optimum performance and reduction of operational costs and costs of ownership.

Main types of rolling bearings and performance comparison

- Particularly excellent
 - Excellent
 - Highly possible
 - Possible
 - Poor
- Indicates dual direction
 - Indicates single direction axial movement only
- Indicates movement in the axial direction is possible for the raceway surface
 - Indicates movement in the axial direction is possible for the fitting surface of the outer ring or inner ring
- Indicates both inner ring and outer ring are separable
- Indicates inner ring with tapered bore is possible

Characteristics		Bearing type	Deep groove ball bearings	Angular contact ball bearings	Double row angular contact ball bearings	Duplex angular contact ball bearings	Self-aligning ball bearings	Cylindrical roller bearings	Singleflange cylindrical roller bearings	Double-flange cylindrical roller bearings	Needle roller bearings	Tapered roller bearings	Spherical roller bearings	Thrust ball bearings	Thrust cylindrical roller bearings	Thrust spherical roller bearings
Load capacity	Radial load (1.)															
	Axial load (1.)	Both directions	One direction	Both directions	Both directions	Both directions	Both directions		One direction	Both directions		One direction	Both directions	One direction	One direction	One direction
	Combined load (1.)															
High speed rotation (1.)																
Accuracy under high speed (1.)																
Low noise/vibration (1.)																
Low friction torque (1.)																
High rigidity (1.)																
Vibration/shock resistance (1.)																
Allowable misalignment for inner/outer rings (1.)																
Stationary in axial direction (2.)																
Movable in axial direction (3.)																
Separable of inner and outer rings (4.)																
Tapered bore inner rings (5.)																
Remarks		Duplex arrangement required					NU, N type	NJ, NF type	NUP, NP, NH type	NA type	Duplex arrangement required				Including thrust needle roller bearing	

Bearing Designation

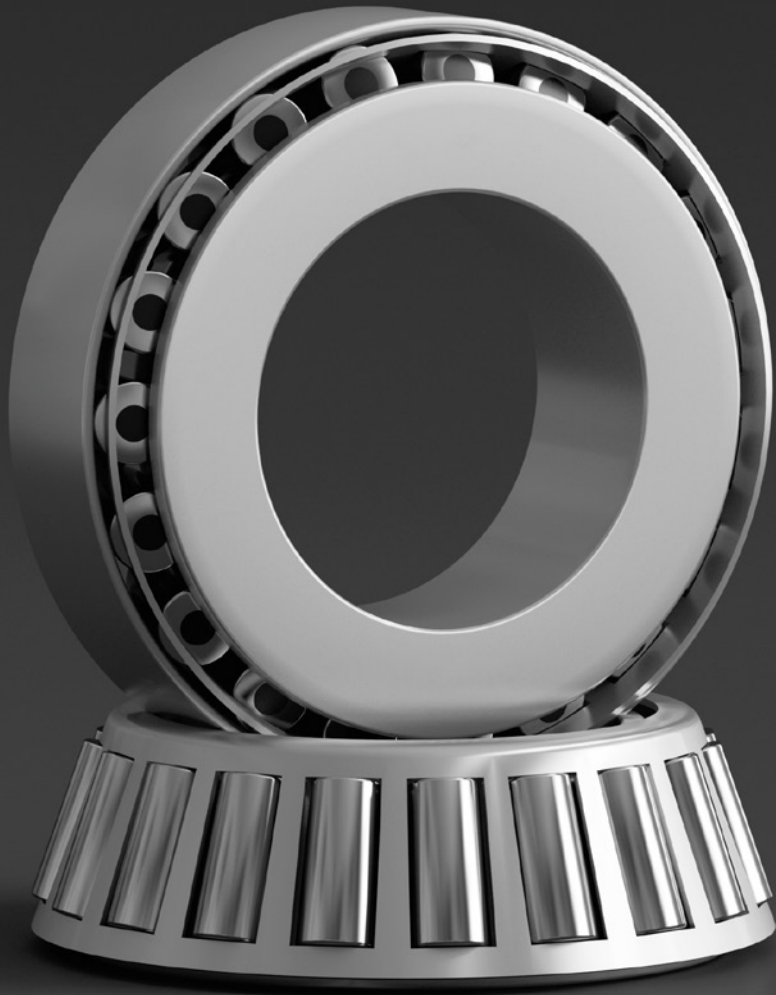

Boundary dimensions and bearing designation codes

Bearing boundary dimensions are dimensions required for bearing installation with shaft or housing and as described in the pictures below. They include the bore diameter, outside diameter, width, height and some other dimensions.

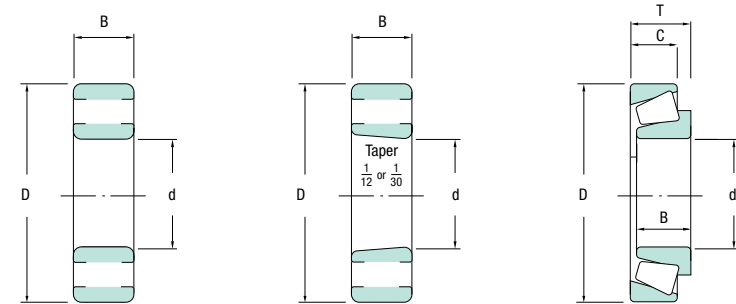

Radial bearing (tapered roller bearings not included)

d: nominal bore diameter

D: nominal outside diameter

B: nominal assembled bearing width

Tapered roller bearing

d: nominal bore diameter

D: nominal outside diameter

T: nominal assembled bearing width

B: nominal inner ring width

C: nominal outer ring width

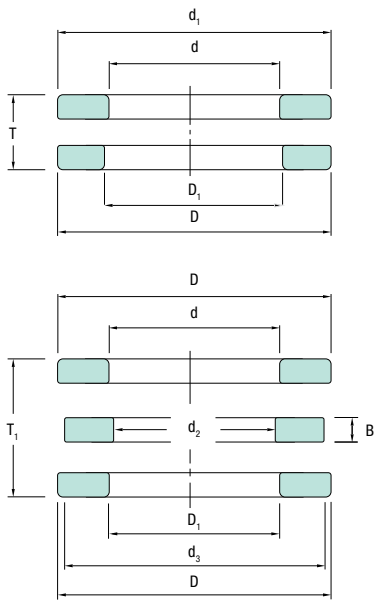

Thrust bearing (single/double direction)	
d:	shaft race nominal bore diameter
d1:	shaft race nominal outside diameter
d2:	central race nominal bore diameter
d3:	central race nominal outside diameter
D:	housing race nominal outside diameter
D1:	housing race nominal bore diameter
T:	single direction nominal bearing height
T1:	double direction nominal bearing height
B:	central race nominal height

The boundary dimensions for metric bearings are standardised in the ISO general plans:

- ISO 15 for radial rolling bearings, except insert bearings, some types of needle roller bearings and tapered roller bearings
- ISO 104 for thrust bearings
- ISO 355 for tapered roller bearings

The ISO general plan for radial bearings provides several series of standardised outside diameters for every standard bore diameter. They are called diameter series and are numbered 7, 8, 9, 0, 1, 2, 3 and 4 (in order of increasing outside diameter). Within each diameter series, different width series exist (width series 8, 0, 1, 2, 3, 4, 5 and 6 in order of increasing width).

THE STANDARD CLASSIFICATION SYSTEM INCLUDES:

- Prefixes
- Base designation
- suffixes

Bearings according to ISO general plans have the same boundary dimensions when they share the same bore diameter and dimension series.

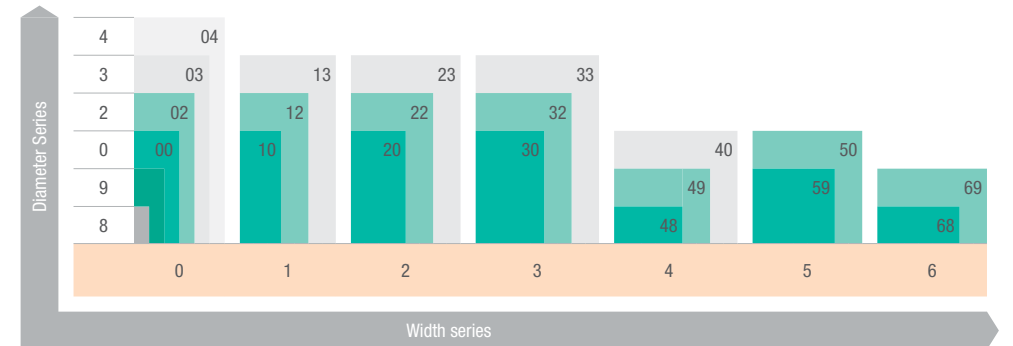
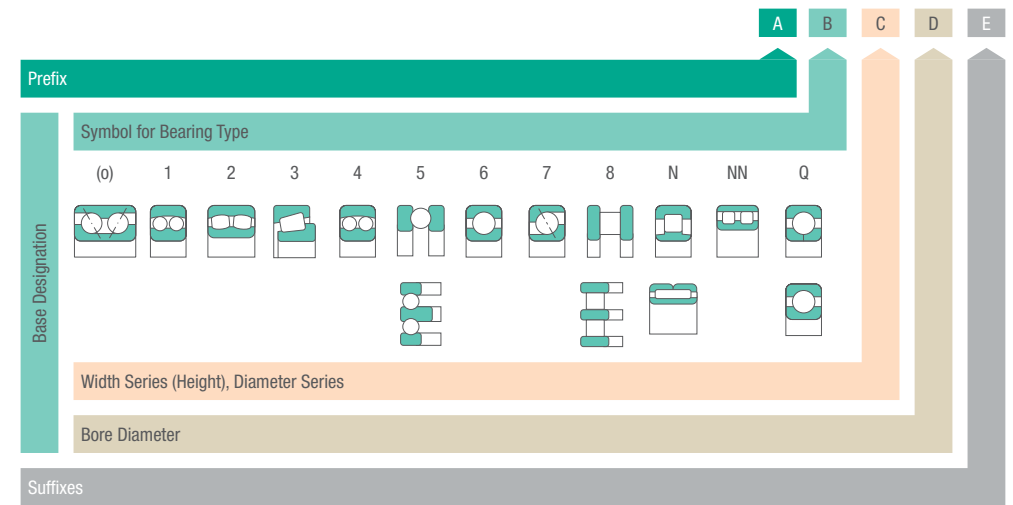

Bearings according to ISO general plans have the same boundary dimensions when they share the same bore diameter and dimension series.

Bearing base designation

A bearing designation typically contains three to five digits. The basic designation explained above is a combination of number and letters with the following meaning:

- First digit/letter/combination of letters identifies the bearing type and a basic variant.
- The following two digits identify the ISO dimension series. The first digit indicates the width or height series (dimensions B, T or H). The second digit identifies the diameter series (dimension D).
- Last two digits of the basic designation identify the size code of the bearing bore.

Prefixes and Suffixes

Prefixes provide and identify separate parts of bearings and the material they are made from. Suffixes give some additional details related to bearing design, variant, tolerance class, clearance class, lubricant used, etc. Suffixes must be always considered in relation to the bearing type and not all suffixes are standardised.

EXAMPLES:

Examples of most common prefixes used	Examples of most common suffixes used
SS - bearing made from Stainless Steel	RS – Bearing with seal on one side
	2RS - Bearing with seals on both sides
	Z – Bearing with shield on one side - metal
	ZZ – Bearing with shields on both sides - metal
	Cx – radial clearance (x = clearance class)
	M – solid brass cage design
	TN – polyamide cage design
	MB – inner ring guided solid brass cage
	Px – tolerance class per ISO 492
	Sx - Thermally stabilised for operating temperatures

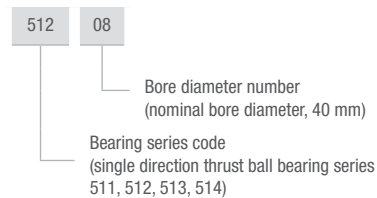
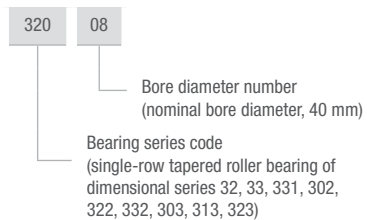
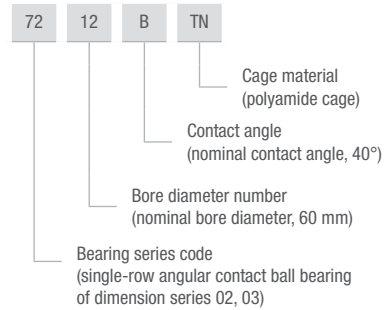
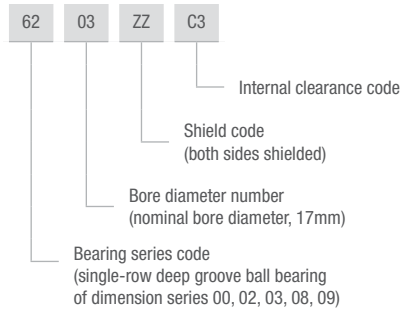
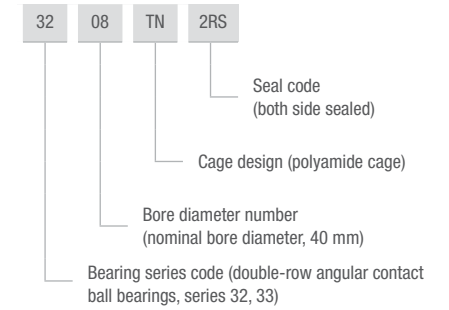
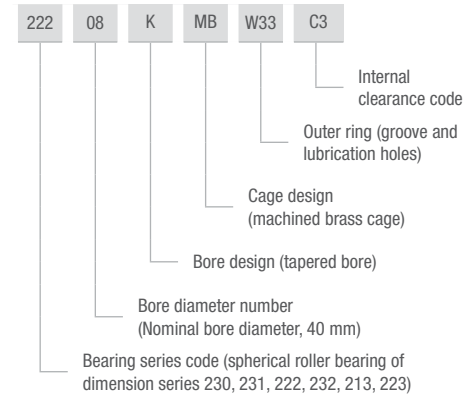
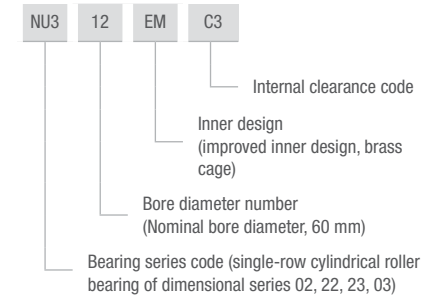
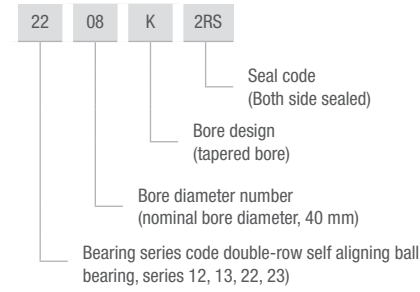

Materials

The rings of the bearings and rolling elements are made of special chrome steel. For environments where increased corrosion resistance is necessary, stainless steels are used. In relation to standard chrome steel used for bearings, stainless steel has lower hardness, which results in reduced load capacity.

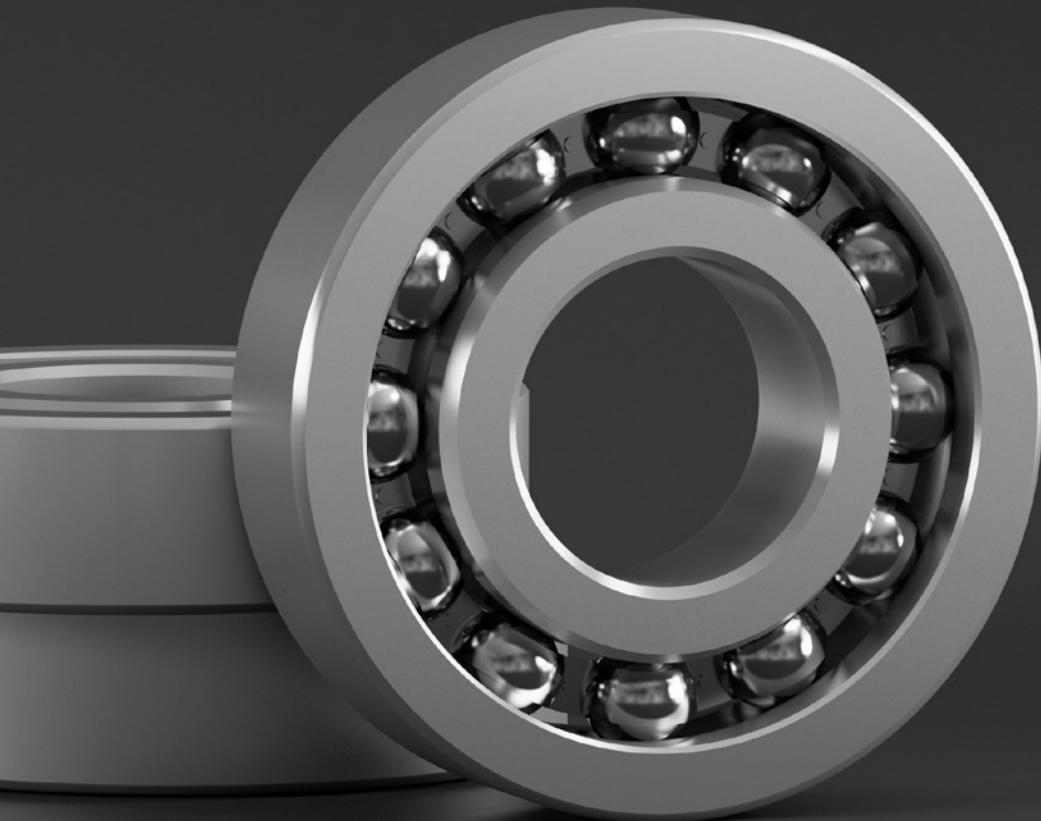

BEARING STEEL EQUIVALENTS

Country	USA	German/ ISO	Japan	China
Standard	ASTM A295	EN ISO 683-17	JIS G4805	GB/T 18254
Grades	52100	100Cr6/1.3505	SUJ2	GCr15

CHINA GRADE BEARING STEEL COMPOSITION

Chemical Composition (%)										
Steel Grade	C	Si	Mn	Cr	Mo ≤	Ni ≤	Cu ≤	P ≤	S ≤	Others
GCr15	0.95-1.05	0.15-0.35	0.25-0.45	1.40-1.65	0.10	0.25	0.25	0.025	0.02	-

Materials are normally thermally processed so that they are stable up to temperatures of 150°C. For bearings that constantly operate at higher temperatures, special heat treatment and thermal stabilisation is required.

THERMAL STABILISATION CLASSES

Thermal stabilisation	
to max.	Class
120°C	SN
150°C	S0
200°C	S1
250°C	S2
300°C	S3

With normal temperature stability up to 150°C, the following normal hardness of components is achieved:

Rings	58-64 HRC
Rolling elements	58-64 HRC

Cage material:

STEEL SHEET

Pressed steel cages are the standard option for various types of bearings such as deep groove ball bearings and tapered roller bearings. Suffix for pressed steel cage is not presented in the bearing description.

Pressed steel cages are made from mild steel. Multiple cage designs are riveted or welded together.

POLYAMIDE

Polyamide is the most commonly used material for injection moulded cages. Polyamide cages, with or without glass fibres, are characterised by a favourable

combination of strength and elasticity. They are designed as snap-type cage or as a solid window-type cage. Cage life is subject to temperature and lubricants used and it decreases with temperature increase and the aggressiveness of the lubricant.

Polyamide loses elasticity at low temperatures, therefore cages made of polyamide should not be used in applications where the continuous operating temperature is below -40°C .

BRASS

Brass cages are unaffected by most common bearing lubricants. Most brass cages are machined from cast or wrought brass; some cages are made from stamped brass sheet and are used for small and medium size bearings.

Seals:

Standard seals are made from NBR rubber and are suitable for operating temperatures from -30°C up to $+120^{\circ}\text{C}$. For specific applications and other temperature conditions other materials are available.

DIFFERENT SEAL MATERIALS AND THEIR TEMPERATURE RANGE

Seal material		Temperature-range	
Symbol	Material	>	≤
NBR	Nitrile-Butadien-rubber	-30°C (-22°F)	$+120^{\circ}\text{C}$ ($+248^{\circ}\text{F}$)
ACM	Acrylic rubber	-20°C (-4°F)	$+150^{\circ}\text{C}$ ($+302^{\circ}\text{F}$)
MVQ	Silicon rubber	-60°C (-76°F)	$+180^{\circ}\text{C}$ ($+356^{\circ}\text{F}$)
FPM	Flour rubber	-30°C (-22°F)	$+200^{\circ}\text{C}$ ($+392^{\circ}\text{F}$)

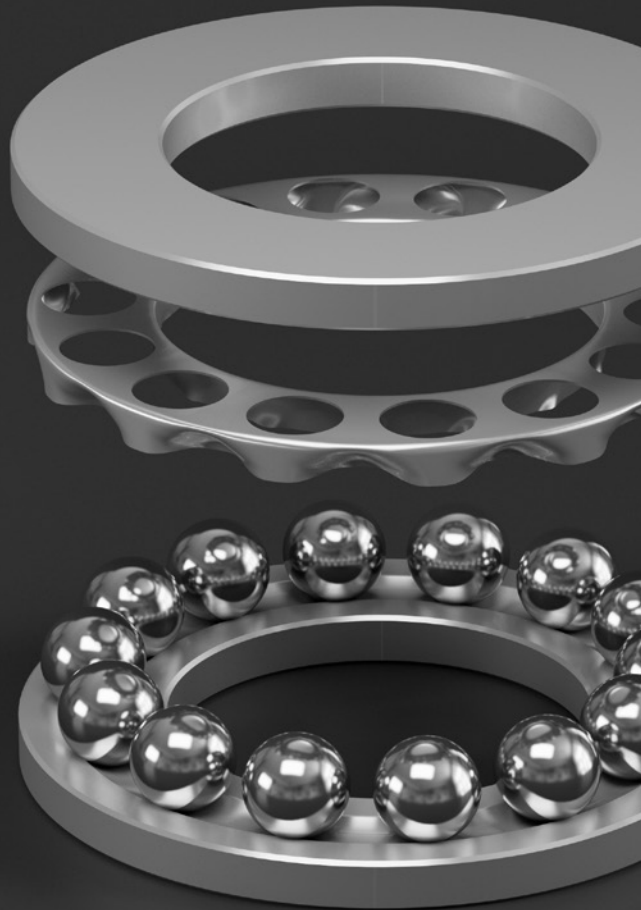

Bearing manufacturing tolerances

Bearings are produced according to international standards, however certain characteristics are not necessarily identical. The tolerance class when indicated on the bearing imposes compliance within all the tolerances in the said class. For certain bearing applications, specific tolerances for dimension or characteristics are required.

BEARING MANUFACTURING PRECISION STANDARDS

	ISO tolerance class	AFNOR tolerance class	ABEC tolerance class	DIN tolerance class
Standard precision	Normal	Normal	1	P0
High Precision	6	6	3	P6
	5	5	5	P5
	4	4	7	P4
	2	2	9	P2

CODEX can offer reduced tolerances on certain dimensions or characteristics to avoid expensive high-precision bearings.

CHARACTERISTICS DESIGNATION AND EXPLANATION

Dimensional tolerances	Deviations
<p>d: nominal bore diameter</p>	<p>Δdmp Deviation of a mean bore diameter in an isolated plane (tolerance on the mean diameter)</p> <p>Vdp Variation in the bore diameter in an isolated radial plane (ovality)</p> <p>Vdmp Variation in the mean bore diameter (applies only to a cylindrical bore) in different planes</p>
<p>D: nominal outside diameter</p>	<p>ΔDmp Deviation of a mean outside diameter in an isolated plane (tolerance on the mean diameter)</p> <p>Vdp Variation in the outside diameter in an isolated radial plane (ovality)</p> <p>VDmp Variation in the mean outside diameter in different planes</p>
<p>B: nominal width of ring</p>	<p>ΔBs Deviation of an isolated width of the inner ring (width tolerance)</p> <p>VBs Variation in the width of the inner ring (face parallelism)</p>

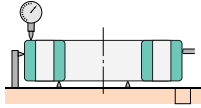
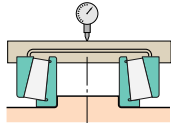
Dimensional tolerances	Deviations
<p>C: nominal width of ring</p> 	<p>ΔCs Deviation of an isolated width of the outer ring (width tolerance)</p> <p>VCs Variation in the width of the outer ring (face parallelism)</p>
<p>T: nominal width of tapered bearing T1: effective nominal width of the internal sub-assembly T2: effective nominal width of the external sub-assembly</p> 	<p>ΔTs Deviation in the actual width of the bearing</p> <p>ΔT1s Deviation in the effective actual width of the internal sub-assembly</p> <p>ΔT2s Deviation in the effective actual width of the external sub-assembly</p>

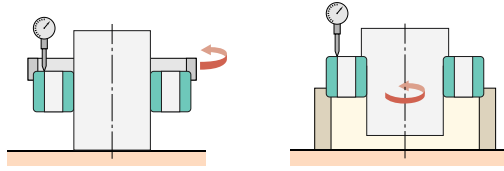
Functional tolerances	Deviations
<p>bearing raceway run-out</p> 	<p>Sea Axial run-out of the reference face (or large face) of the outer ring with respect to the bearing raceway, on the assembled bearing (run-out of outer ring raceway)</p> <p>Sia Axial run-out of the inner ring with respect to the bearing raceway on the assembled bearing (run-out of the inner ring raceway)</p>

Radial bearings – Normal tolerance classes

With the exception of tapered roller bearings and thrust bearings. Standard ISO 492.

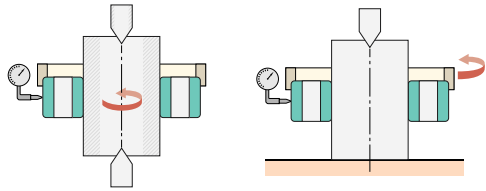
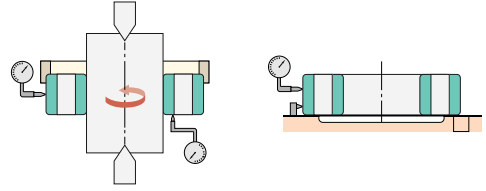
Functional tolerances	Deviations
<p>radial run-out</p> 	<p>Kia Radial run-out of the inner ring on the assembled bearing</p> <p>Kea Radial run-out of the outer ring on the assembled bearing</p>
<p>run-out of the reference face</p> 	<p>Sd Axial run-out of the reference face (or large face it applicable) of the inner ring with respect to the bore (run-out of the face of the inner ring)</p> <p>SD Perpendicularity error of the external surface with respect to the reference face (or large face) of the outer ring (external surface run-out)</p>

INNER RING

Units: μm

d (mm)	Δdmp		Vdp ⁽¹⁾			Vdmp	Kia	ΔBs			VBs
			Series					all	normal	modified ⁽¹⁾	
	upper	lower	9	0,1	2,3,4	max	max				upper
0,6 ≤ d ≤ 2,5	0	-8	10	8	6	6	10	0	-40	-	12
2,5 < d ≤ 10	0	-8	10	8	6	6	10	0	-120	-250	15
10 < d ≤ 18	0	-8	10	8	6	6	10	0	-120	-250	20
18 < d ≤ 30	0	-10	13	10	8	8	13	0	-120	-250	20
30 < d ≤ 50	0	-12	15	12	9	9	15	0	-120	-250	20
50 < d ≤ 80	0	-15	19	19	11	11	20	0	-150	-380	25
80 < d ≤ 120	0	-20	25	25	15	15	25	0	-200	-380	25
120 < d ≤ 180	0	-25	31	31	19	19	30	0	-250	-500	30
180 < d ≤ 250	0	-30	38	38	23	23	40	0	-300	-500	30
250 < d ≤ 315	0	-35	44	44	26	26	50	0	-350	-500	35
315 < d ≤ 400	0	-40	50	50	30	30	60	0	-400	-630	40
400 < d ≤ 500	0	-45	56	56	34	34	65	0	-450	-	50
500 < d ≤ 630	0	-50	63	63	38	38	70	0	-500	-	60
630 < d ≤ 800	0	-75	-	-	-	-	80	0	-750	-	70
800 < d ≤ 1000	0	-100	-	-	-	-	90	0	-1000	-	80

(1) relates to the rings of isolated bearings for installation in pairs or per unit

OUTER RING

Units: μm

D (mm)	ΔDmp		$\text{VDp}^{(1)}$				$\text{VDmp}^{(1)}$	Kea	ΔCs $\Delta\text{C1s}^{(2)}$		VCs $\text{VC1s}^{(2)}$
			Open bearings		Shielded bearings						
			Series								
	9	0,1	2,3,4	2,3,4	max	max	upper	lower	max		
2,5 \leq D \leq 6	0	-8	10	8	6	10	6	15	Identical to ΔBs and VBs of the inner ring of the same bearing		
6<D \leq 18	0	-8	10	8	6	10	6	15			
18<D \leq 30	0	-9	12	9	7	12	7	15			
30<D \leq 50	0	-11	14	11	8	16	8	20			
50<D \leq 80	0	-13	16	13	10	20	10	25			
80<D \leq 120	0	-15	19	19	11	26	11	35			
120<D \leq 150	0	-18	23	23	14	30	14	40			
150<D \leq 180	0	-25	31	31	19	38	19	45			
180<D \leq 250	0	-30	38	38	23	-	23	50			
250<D \leq 315	0	-35	44	44	26	-	26	60			
315<D \leq 400	0	-40	50	50	30	-	30	70			
400<D \leq 500	0	-45	56	56	34	-	34	80			
500<D \leq 630	0	-50	63	63	38	-	38	100			
630<D \leq 800	0	-75	94	94	55	-	55	120			
800<D \leq 1000	0	-100	125	125	75	-	75	140			

Note: the tolerances on the outside diameter D1 of the flange on the outer ring are given in standard ISO 492.

- (1) taken before fitting and after removal of the inner or outer snap ring
 (2) only applies to ball and grooved bearings

High precision radial bearings – Tolerance class 6

With the exception of tapered roller bearings and thrust bearings. Standard ISO 492.

INNER RING

Units: μm

d (mm)	Δdmp		Vdp			Vdmp	Kia	ΔBs			VBs
			Series					all	normal	modified ⁽¹⁾	
			9	0,1	2,3,4						
	upper	lower	max			max	max	upper	lower	max	
0,6 \leq d \leq 2,5	0	-7	9	7	5	5	5	0	-40	-	12
2,5<d \leq 10	0	-7	9	7	5	5	6	0	-120	-250	15
10<d \leq 18	0	-7	9	7	5	5	7	0	-120	-250	20
18<d \leq 30	0	-8	10	8	6	6	8	0	-120	-250	20
30<d \leq 50	0	-10	13	10	8	8	10	0	-120	-250	20
50<d \leq 80	0	-12	15	15	9	9	10	0	-150	-380	25
80<d \leq 120	0	-15	19	19	11	11	13	0	-200	-380	25
120<d \leq 180	0	-18	23	23	14	14	18	0	-250	-500	30
180<d \leq 250	0	-22	28	28	17	17	20	0	-300	-500	30
250<d \leq 315	0	-25	31	31	19	19	25	0	-350	-500	35
315<d \leq 400	0	-30	38	38	23	23	30	0	-400	-630	40
400<d \leq 500	0	-35	44	44	26	26	35	0	-450	-	45
500<d \leq 630	0	-40	50	50	30	30	40	0	-500	-	50

- (1) Relates to the rings of isolated bearings for installation in pairs or per unit

OUTER RING

Units: μm

D (mm)	ΔDmp		$\text{VDp}^{(1)}$				$\text{VDmp}^{(1)}$	Kea	ΔCs $\Delta\text{C1s}^{(2)}$		VCs $\text{VC1s}^{(2)}$
			Open bearings		Shielded bearings						
			Series								
	9	0,1	2,3,4	0,1,2,3,4	max	max	upper	lower	max		
2,5 \leq D \leq 6	0	-7	9	7	5	9	5	8	Identical to ΔBs and VBs of the inner ring of the same bearing		
6<D \leq 18	0	-7	9	7	5	9	5	8			
18<D \leq 30	0	-8	10	8	6	10	6	9			
30<D \leq 50	0	-9	11	9	7	13	7	10			
50<D \leq 80	0	-11	14	11	8	16	8	13			
80<D \leq 120	0	-13	16	16	10	20	10	18			
120<D \leq 150	0	-15	19	19	11	25	11	20			
150<D \leq 180	0	-18	23	23	14	30	14	23			
180<D \leq 250	0	-20	25	25	15	-	15	25			
250<D \leq 315	0	-25	31	31	19	-	19	30			
315<D \leq 400	0	-28	35	35	21	-	21	35			
400<D \leq 500	0	-33	41	41	25	-	25	40			
500<D \leq 630	0	-38	48	48	29	-	29	50			
630<D \leq 800	0	-45	56	56	34	-	34	60			
800<D \leq 1000	0	-60	75	75	45	-	45	75			

Note: the tolerances on the outside diameter D1 of the flange on the outer ring are given in standard ISO 492.

- (1) taken before fitting and after removal of the inner or outer snap ring
 (2) only applies to ball and grooved bearings

High precision radial bearings – Tolerance class 5

With the exception of tapered roller bearings and thrust bearings. Standard ISO 492.

INNER RING

Units: μm

d (mm)	Δdmp		Vdp		Vdmp	Kia	Sd	Sia ⁽¹⁾	ΔBs			VBs
			Series						all	normal	modified ⁽²⁾	
			9	0,1, 2,3,4								
	upper	lower	max		max	max	max	upper	lower		max	
0,6≤d≤2,5	0	-5	5	4	3	4	7	7	0	-40	-250	5
2,5<d≤10	0	-5	5	4	3	4	7	7	0	-40	-250	5
10<d≤18	0	-5	5	4	3	4	7	7	0	-80	-250	5
18<d≤30	0	-6	6	5	3	4	8	8	0	-120	-250	5
30<d≤50	0	-8	8	6	4	5	8	8	0	-120	-250	5
50<d≤80	0	-9	9	7	5	5	8	8	0	-150	-250	6
80<d≤120	0	-10	10	8	5	6	9	9	0	-200	-380	7
120<d≤180	0	-13	13	10	7	8	10	10	0	-250	-380	8
180<d≤250	0	-15	15	12	8	10	11	13	0	-300	-500	10
250<d≤315	0	-18	18	14	9	13	13	15	0	-350	-500	13
315<d≤400	0	-23	23	18	12	15	15	20	0	-400	-630	15

(1) Only applies to ball and grooved bearings.

(2) Relates to the rings of isolated bearings for installation in pairs or per unit.

OUTER RING

Units: μm

D (mm)	ΔDmp		VDp		VDmp	Kea	SD ⁽¹⁾ SD1 ⁽²⁾	Sea ^(1,2)	Sea1 ⁽²⁾	ΔCs $\Delta\text{C1s}^{(2)}$		VCs VC1s ⁽²⁾
			Series							upper	lower	
			9	0,1, 2,3,4								
	upper	lower	max		max	max	max	max	max	max		
2,5≤D≤6	0	-5	5	4	3	5	8	8	11	Identical to ΔBs and VBs of the inner ring of the same bearing	5	
6<D≤18	0	-5	5	4	3	5	8	8	11		5	
18<D≤30	0	-5	6	5	3	6	8	8	11		5	
30<D≤50	0	-7	7	5	4	7	8	8	11		5	
50<D≤80	0	-9	9	7	5	8	8	10	14		6	
80<D≤120	0	-10	10	8	5	10	9	11	16		8	
120<D≤150	0	-11	11	8	6	11	10	13	18		8	
150<D≤180	0	-13	13	10	7	13	10	14	20		8	
180<D≤250	0	-15	15	11	8	15	11	15	21		10	
250<D≤315	0	-18	18	14	9	18	13	18	25		11	
315<D≤400	0	-20	20	15	10	20	13	20	28		13	
400<D≤500	0	-23	23	17	12	23	15	23	33		15	
500<D≤630	0	-28	28	21	14	25	18	25	35		18	
630<D≤800	0	-35	35	26	18	30	20	30	42		20	

Note: The tolerances on the outside diameter, D1, of the flange on the outer ring are given in standard ISO 492.

(1) Does not apply to bearings with a flange-type outer ring.

(2) Only applies to ball and grooved bearings.

High precision radial bearings – Tolerance class 4

With the exception of tapered roller bearings and thrust bearings. Standard ISO 492.

INNER RING

Units: μm

d (mm)	$\Delta\text{dmp}^{(1)}$		Δds		Vdp ⁽¹⁾		Vdmp	Kia	Sd	Sia ⁽²⁾	ΔBs			VBs
					Series						all	normal	modified ⁽²⁾	
					9	0,1,2,3,4								
	upper	lower	upper	lower	max		max	max	max	max	upper	lower		max
0,6≤d≤2,5	0	-4	0	-4	4	3	2	2,5	3	3	0	-40	-250	2,5
2,5<d≤10	0	-4	0	-4	4	3	2	2,5	3	3	0	-40	-250	2,5
10<d≤18	0	-4	0	-4	4	3	2	2,5	3	3	0	-80	-250	2,5
18<d≤30	0	-5	0	-5	5	4	2,5	3	4	4	0	-120	-250	2,5
30<d≤50	0	-6	0	-6	6	5	3	4	4	4	0	-120	-250	3
50<d≤80	0	-7	0	-7	7	5	3,5	4	5	5	0	-150	-250	4
80<d≤120	0	-8	0	-8	8	6	4	5	5	5	0	-200	-380	4
120<d≤180	0	-10	0	-10	10	8	5	6	6	7	0	-250	-380	5
180<d≤250	0	-12	0	-12	12	9	6	8	7	8	0	-300	-500	6

(1) These differences apply to diameter series 0, 1, 2, 3 and 4 only.

(2) Only applies to ball and grooved bearings

(3) Relates to the rings of isolated bearings for installation in pairs or per unit.

OUTER RING

Units: μm

D (mm)	ΔDmp		$\Delta\text{Ds}^{(1)}$		VDp ⁽¹⁾		VDmp	Kea	Sd ⁽²⁾ Sd1 ⁽³⁾	Sea ^(2,3)	Sea1 ⁽³⁾	ΔCs $\Delta\text{C1s}^{(3)}$		VCs VC1s ⁽³⁾
					Series							upper	lower	
					9	0,1,2,3,4								
	upper	lower	upper	lower	max		max	max	max	max	max	max		
2,5≤D≤6	0	-4	0	-4	4	3	2	3	4	5	7	Identical to ΔBs of the inner ring of the same bearing	2,5	
6<D≤18	0	-4	0	-4	4	3	2	3	4	5	7		2,5	
18<D≤30	0	-5	0	-5	5	4	2,5	4	4	5	7		2,5	
30<D≤50	0	-6	0	-6	6	5	3	5	4	5	7		2,5	
50<D≤80	0	-7	0	-7	7	5	3,5	5	4	5	7		3	
80<D≤120	0	-8	0	-8	8	6	4	6	5	6	8		4	
120<D≤150	0	-9	0	-9	9	7	5	7	5	7	10		5	
150<D≤180	0	-10	0	-10	10	8	5	8	5	8	11		5	
180<D≤250	0	-11	0	-11	11	8	6	10	7	10	14		7	
250<D≤315	0	-13	0	-13	13	10	7	11	8	10	14		7	
315<D≤400	0	-15	0	-15	15	11	8	13	10	13	18		8	

Note: The tolerances on the outside diameter, D1, of the flange on the outer ring are given in standard ISO 492.

(1) These differences apply to diameter series 0, 1, 2, 3 and 4 only.

(2) Only applies to ball and grooved bearings.

(3) Relates to the rings of isolated bearings for installation in pairs or per unit.

High precision radial bearings – Tolerance class 2

With the exception of tapered roller bearings and thrust bearings. Standard ISO 492.

INNER RING

Units: μm

d (mm)	Δdmp		Δds		$\text{Vdp}^{(1)}$	Vdmp	Kia	Sd	$\text{Sia}^{(2)}$	ΔBs			VBs
	upper	lower	upper	lower	max	max	max	max	max	all	normal	modified ⁽³⁾	
										upper	lower		
0.6<d≤2.5	0	-2.5	0	-2.5	2.5	1.5	1.5	1.5	1.5	0	-40	-250	1.5
2.5<d≤10	0	-2.5	0	-2.5	2.5	1.5	1.5	1.5	1.5	0	-40	-250	1.5
10<d≤18	0	-2.5	0	-2.5	2.5	1.5	1.5	1.5	1.5	0	-80	-250	1.5
18<d≤30	0	-2.5	0	-2.5	2.5	1.5	2.5	1.5	2.5	0	-120	-250	1.5
30<d≤50	0	-2.5	0	-2.5	2.5	1.5	2.5	1.5	2.5	0	-120	-250	1.5
50<d≤80	0	-4	0	-4	4	2	2.5	1.5	2.5	0	-150	-250	1.5
80<d≤120	0	-5	0	-5	5	2.5	2.5	2.5	2.5	0	-200	-380	2.5
120<d≤150	0	-7	0	-7	7	3.5	2.5	2.5	2.5	0	-250	-380	2.5
150<d≤180	0	-7	0	-7	7	3.5	5	4	5	0	-250	-380	4
180<d≤250	0	-8	0	-8	8	4	5	5	5	0	-300	-500	5

- (1) These differences apply to diameter series 0, 1, 2, 3 and 4 only.
 (2) Only applies to ball and grooved bearings
 (3) Relates to the ring of isolated bearings for installation in pairs or per unit.

OUTER RING

Units: μm

D (mm)	ΔDmp		ΔDs		$\text{VDp}^{(1)}$	VDp	Kea	$\text{Sd}^{(2)}$ $\text{Sd1}^{(3)}$	$\text{Sia}^{(2,3)}$	$\text{Sia1}^{(3)}$	ΔCs $\Delta\text{C1s}^{(3)}$		VCs $\text{VC1s}^{(3)}$
	upper	lower	upper	lower	max	max	max	max	max	max	upper	lower	max
											Identical to ΔBs of the inner ring of the same bearing		max
2.5≤D≤6	0	-2.5	0	-2.5	2.5	1.5	1.5	1.5	1.5	3			1.5
6<D≤18	0	-2.5	0	-2.5	2.5	1.5	1.5	1.5	1.5	3			1.5
18<D≤30	0	-4	0	-4	4	2	2.5	1.5	2.5	4			1.5
30<D≤50	0	-4	0	-4	4	2	2.5	1.5	2.5	4			1.5
50<D≤80	0	-4	0	-4	4	2	4	1.5	4	6			1.5
80<D≤120	0	-5	0	-5	5	2.5	5	2.5	5	7			2.5
120<D≤150	0	-5	0	-5	5	2.5	5	2.5	5	7			2.5
150<D≤180	0	-7	0	-7	7	3.5	5	2.5	5	7			2.5
180<D≤250	0	-8	0	-8	8	4	7	4	7	10			4
250<D≤315	0	-8	0	-8	8	4	7	5	7	10			5
315<D≤400	0	-10	0	-10	10	5	8	7	8	11			7

Note: The tolerances on the outside diameter, D1, of the flange on the outer ring are given in standard ISO 492.

- (1) These differences apply to diameter series 0, 1, 2, 3 and 4 only.
 (2) Only applies to ball and grooved bearings
 (3) Relates to the ring of isolated bearings for installation in pairs or per unit.

Tapered roller bearings – Normal tolerance class

DIAMETER AND RADIAL RUN-OUT – INNER RING

Units: μm

d (mm)	Δdmp		Vdp	Vdmp	Kia
	upper	lower	max	max	max
10≤d≤18	0	-12	12	9	15
18<d≤30	0	-12	12	9	18
30<d≤50	0	-12	12	9	20
50<d≤80	0	-15	15	11	25
80<d≤120	0	-20	20	15	30
120<d≤180	0	-25	25	19	35
180<d≤250	0	-30	30	23	50
250<d≤315	0	-35	35	26	60
315<d≤400	0	-40	40	30	70

DIAMETER AND RADIAL RUN-OUT – OUTER RING

Units: μm

D (mm)	ΔDmp		VDp	VDmp	Kea
	upper	lower	max	max	max
18≤D≤30	0	-12	12	9	18
30<D≤50	0	-14	14	11	20
50<D≤80	0	-16	16	12	25
80<D≤120	0	-18	18	14	35
120<D≤150	0	-20	20	15	40
150<D≤180	0	-25	25	19	45
180<D≤250	0	-30	30	23	50
250<D≤315	0	-35	35	26	60
315<D≤400	0	-40	40	30	70
400<D≤500	0	-45	45	34	80
500<D≤630	0	-50	50	38	100

The tolerances on the outside diameter (D1) of the flange on the outer ring are given in standard ISO 492.

WIDTH- INNER AND OUTER RINGS, SINGLE-ROW BEARINGS AND SINGLE-ROW SUB-ASSEMBLIES

Units: μm

d (mm)	ΔBs		ΔCs		ΔTs		ΔT1s		ΔT2s	
	upper	lower	upper	lower	upper	lower	upper	lower	upper	lower
10≤d≤18	0	-120	0	-120	+200	0	+100	0	+100	0
18<d≤30	0	-120	0	-120	+200	0	+100	0	+100	0
30<d≤50	0	-120	0	-120	+200	0	+100	0	+100	0
50<d≤80	0	-150	0	-150	+200	0	+100	0	+100	0
80<d≤120	0	-200	0	-200	+200	-200	+100	-100	+100	-100
120<d≤180	0	-250	0	-250	+350	-250	+150	-150	+200	-100
180<d≤250	0	-300	0	-300	+350	-250	+150	-150	+200	-100
250<d≤315	0	-350	0	-350	+350	-250	+150	-150	+200	-100
315<d≤400	0	-400	0	-400	+400	-400	+200	-200	+200	-200

High precision tapered roller bearings – Tolerance class 6X

The diameter and radial run-out tolerances of inner rings (cones) and outer rings (cups) in this tolerance class are the same as those given in page 54 for the normal class. The width tolerances are given below.

WIDTH – INNER AND OUTER RINGS, SINGLE-ROW BEARINGS AND SINGLE-ROW SUB-ASSEMBLIES.

Units: μm

d (mm)	ΔBs		ΔCs		ΔTs		ΔT1s		ΔT2s	
	upper	lower	upper	lower	upper	lower	upper	lower	upper	lower
10 \leq d \leq 18	0	-50	0	-100	+100	0	+50	0	+50	0
18<d \leq 30	0	-50	0	-100	+100	0	+50	0	+50	0
30<d \leq 50	0	-50	0	-100	+100	0	+50	0	+50	0
50<d \leq 80	0	-50	0	-100	+100	0	+50	0	+50	0
80<d \leq 120	0	-50	0	-100	+100	0	+50	0	+50	0
120<d \leq 180	0	-50	0	-100	+150	0	+50	0	+100	0
180<d \leq 250	0	-50	0	-100	+150	0	+50	0	+100	0
250<d \leq 315	0	-50	0	-100	+200	0	+100	0	+100	0
315<d \leq 400	0	-50	0	-100	+200	0	+100	0	+100	0

Ball thrust bearings – Normal tolerance class

Standard ISO 199.

REFERENCES

d	Nominal bore diameter of the shaft ring of a single-direction thrust bearing	
Δdmp	Deviation in the mean bore diameter of the shaft ring of a single-direction thrust bearing, in an isolated plane	
Vdp	Variation in the bore diameter of the shaft ring of a single-direction thrust bearing, in an isolated radial plane	
D	Nominal outside diameter of the housing ring	
ΔDmp	Deviation in the mean outside diameter of the housing ring in an isolated plane	
VDp	Variation in the outside diameter of the housing ring in an isolated radial plane	
Si	Variation in thickness between the bearing raceway and the contact face of the shaft ring	
Se	Variation in thickness between the bearing raceway and the contact face of the housing ring	
ΔTs	Variation in total height	

SHAFT RING AND HEIGHT OF THRUST BEARING

Units: μm

d (mm)		Δdmp		Vdp	Si	ΔTs	
>	\leq	upper	lower	max	max	upper	lower
-	18	0	-8	6	10	+20	-250
18	30	0	-10	8	10	+20	-250
30	50	0	-12	9	10	+20	-250
50	80	0	-15	11	10	+20	-300
80	120	0	-20	15	15	+25	-300
120	180	0	-25	19	15	+25	-400
180	250	0	-30	23	20	+30	-400
250	315	0	-35	26	25	+40	-400
315	400	0	-40	30	30	+40	-500
400	500	0	-45	34	30	+50	-500

Internal radial clearance is the load free displacement of one ring with respect to the other in radial direction.

RADIAL CLEARANCE OF RADIAL CONTACT BEARINGS. DEFINITION

The internal radial clearance is the load-free displacement of one ring with respect to the other in the radial direction.

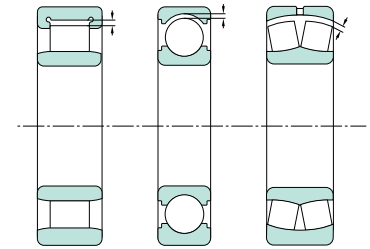

Radial clearance		Bearing designation	Other manufactures
Type	Group	Codex suffix	
Normal clearance	N		Suitable for low or moderate loads, normal interference fit of only one of the two rings, normal temperatures.
Increased clearance	3	C3	Clearance commonly used in the following cases: <ul style="list-style-type: none"> Tight interference fit Possible misalignment, bending of shaft To increase the contact angle of highly-loaded radial contact ball bearings High temperatures
		C4	Clearance groups 4 and 5 are used in the above cases when group 3 is insufficient.
		C5	
Reduced clearance	2	C2	This clearance group is used (rarely) when very good guidance with reduced clearance is required, and in applications with alternating loads and high impact levels. The use of this clearance group is highly particular, because its aim is usually to cancel the bearing operating clearance.

Internal Radial Clearance - Single Row Deep Groove Ball Bearings

Units: μm

Nominal Bore Diameter dmcl (mm)		Clearance									
		C2		Normal		C3		C4		C5	
over	incl	min	max	min	max	min	max	min	max	min	max
10 only		0	7	2	13	8	23	14	29	20	37
10	18	0	9	3	18	11	25	18	33	25	45
18	24	0	10	5	20	13	28	20	36	28	48
24	30	1	11	5	20	13	28	23	41	30	53
30	40	1	11	6	20	15	33	28	46	40	64
40	50	1	11	6	23	18	36	30	51	45	73
50	65	1	15	8	28	23	43	38	61	55	90
65	80	1	15	10	30	25	51	46	71	65	105
80	100	1	18	12	36	30	58	53	84	75	120
100	120	2	20	15	41	36	66	61	97	90	140
120	140	2	23	18	48	41	81	71	114	105	160
140	160	2	23	18	53	46	91	81	130	120	180
160	180	2	25	20	61	53	102	91	147	135	200
180	200	2	30	25	71	63	117	107	163	150	230
200	225	2	35	25	85	75	140	125	195	175	265
225	250	2	40	30	95	85	160	145	225	205	300
250	280	2	45	35	105	90	170	155	245	225	340
280	315	2	55	40	115	100	190	175	270	245	370
315	355	3	60	45	125	110	210	195	300	275	410
355	400	3	70	55	145	130	240	225	340	315	460
400	450	3	80	60	170	150	270	250	380	350	520
450	500	3	90	70	190	170	300	280	420	390	570
500	560	10	100	80	210	190	330	310	470	440	630
560	630	10	110	90	230	210	360	340	520	490	700
630	710	20	130	110	260	240	400	380	570	540	780
710	800	20	140	120	290	270	450	430	630	600	860

Internal Radial Clearance – Extra Small and Miniature Bearings

Units: μm

Clearance symbol	MC1		MC2		MC3		MC4		MC5		MC6	
	min	max	min	max	min	max	min	max	min	max	min	max
Clearance	0	5	3	8	5	10	8	13	13	20	20	28

Internal Radial Clearance - Double Row Self-Aligning Ball Bearings with Cylindrical Bore

Units: μm

Nominal Bore Diameter dmcl (mm)		Clearance									
		C2		CN		C3		C4		C5	
over	incl	min	max	min	max	min	max	min	max	min	max
2.5	6	1	8	5	15	10	20	15	25	21	33
6	10	2	9	6	17	12	25	19	33	27	42
10	14	2	10	6	19	13	26	21	35	30	48
14	18	3	12	8	21	15	28	23	37	32	50
18	24	4	14	10	23	17	30	25	39	34	52
24	30	5	16	11	24	19	35	29	46	40	58
30	40	6	18	13	29	23	40	34	53	46	66
40	50	6	19	14	31	25	44	37	57	50	71
50	65	7	21	16	36	30	50	45	69	62	88
65	80	8	24	18	40	35	60	54	83	76	108
80	100	9	27	22	48	42	70	64	96	89	124
100	120	10	31	25	56	50	83	75	114	105	145
120	140	10	38	30	68	60	100	90	135	125	175
140	160	15	44	35	80	70	120	110	161	150	210

Internal Radial Clearance - Double Row Self-Aligning Ball Bearings with Tapered Bore

Units: μm

Nominal Bore Diameter dmcl (mm)		Clearance									
		C2		CN		C3		C4		C5	
over	incl	min	max	min	max	min	max	min	max	min	max
2.5	6	-	-	-	-	-	-	-	-	-	-
6	10	-	-	-	-	-	-	-	-	-	-
10	14	-	-	-	-	-	-	-	-	-	-
14	18	-	-	-	-	-	-	-	-	-	-
18	24	7	17	13	26	20	33	28	42	37	55
24	30	9	20	15	28	23	39	33	50	44	62
30	40	12	24	19	35	29	46	40	59	52	72
40	50	14	27	22	39	33	52	45	65	58	79
50	65	18	32	27	47	41	61	56	80	73	99
65	80	23	39	35	57	50	75	69	98	91	123
80	100	29	47	42	68	62	90	84	116	109	144
100	120	35	56	50	81	75	108	100	139	130	170
120	140	40	68	60	98	90	130	120	165	155	205
140	160	45	74	65	110	100	150	140	191	180	240

Internal Radial Clearance - Single Row Cylindrical Roller Bearings with Cylindrical Bores

Units: μm

Nominal Bore Diameter dmcl (mm)		Clearance									
		C2		CN		C3		C4		C5	
over	incl	min	max	min	max	min	max	min	max	min	max
-	10	0	25	20	45	35	60	50	75	-	-
10	24	0	25	20	45	35	60	50	75	65	90
24	30	0	25	20	45	35	60	50	75	70	95
30	40	5	30	25	50	45	70	60	85	80	105
40	50	5	35	30	60	50	80	70	100	95	125
50	65	10	40	40	70	60	90	80	110	110	140
65	80	10	45	40	75	65	100	90	125	130	165
80	100	15	50	50	85	75	110	105	140	155	190
100	120	15	55	50	90	85	125	125	165	180	220
120	140	15	60	60	105	100	145	145	190	200	245
140	160	20	70	70	120	115	165	165	215	225	275
160	180	25	75	75	125	120	170	170	220	250	300
180	200	35	90	90	145	140	195	195	250	275	330
200	225	45	105	105	165	160	220	220	280	305	365
225	250	45	110	110	175	170	235	235	300	330	395
250	280	55	125	125	195	190	260	260	330	370	440
280	315	55	130	130	205	200	275	275	350	410	485
315	355	65	145	145	225	225	305	305	385	455	535
355	400	100	190	190	280	280	370	370	460	510	600
400	450	110	210	210	310	310	410	410	510	565	665
450	500	110	220	220	330	330	440	440	550	625	735

Internal Radial Clearance - Double Row Spherical Roller Bearings with Cylindrical Bores

Units: μm

Nominal Bore Diameter dmcl (mm)		Clearance									
		C2		CN		C3		C4		C5	
over	incl	min	max	min	max	min	max	min	max	min	max
24	30	15	25	25	40	40	55	55	75	75	95
30	40	15	30	30	45	45	60	60	80	80	100
40	50	20	35	35	55	55	75	75	100	100	125
50	65	20	40	40	65	65	90	90	120	120	150
65	80	30	50	50	80	80	110	110	145	145	180
80	100	35	60	60	100	100	135	135	180	180	225
100	120	40	75	75	120	120	160	160	210	210	260
120	140	50	95	95	145	145	190	190	240	240	300
140	160	60	110	110	170	170	220	220	280	280	350
160	180	65	120	120	180	180	240	240	310	310	390
180	200	70	130	130	200	200	260	260	340	340	430
200	225	80	140	140	220	220	290	290	380	380	470
225	250	90	150	150	240	240	320	320	420	420	520
250	280	100	170	170	260	260	350	350	460	460	570
280	315	110	190	190	280	280	370	370	500	500	630
315	355	120	200	200	310	310	410	410	550	550	690
355	400	130	220	220	340	340	450	450	600	600	750
400	450	140	240	240	370	370	500	500	660	660	820
450	500	140	260	260	410	410	550	550	720	720	900
500	560	150	280	280	440	440	600	600	780	780	1000
560	630	170	310	310	480	480	650	650	850	850	1100
630	710	190	350	350	530	530	700	700	920	920	1190
710	800	210	390	390	580	580	770	770	1010	1010	1300
800	900	230	430	430	650	650	860	860	1120	1120	1440
900	1000	260	480	480	710	710	930	930	1220	1220	1570
1000	1120	290	530	530	780	780	1020	1020	1330	-	-
1120	1250	320	580	580	860	860	1120	1120	1460	-	-
1250	1400	350	640	640	950	950	1240	1240	1620	-	-

Internal Radial Clearance - Double Row Spherical Roller Bearings with Tapered Bores

Units: μm

Nominal Bore Diameter dmcl (mm)		Clearance									
		C2		CN		C3		C4		C5	
over	incl	min	max	min	max	min	max	min	max	min	max
24	30	20	30	30	40	40	55	55	75	75	95
30	40	25	35	35	50	50	65	65	85	85	105
40	50	30	45	45	60	60	80	80	100	100	130
50	65	40	55	55	75	75	95	95	120	120	160
65	80	50	70	70	95	95	120	120	150	150	200
80	100	55	80	80	110	110	140	140	180	180	230
100	120	65	100	100	135	135	170	170	220	220	280
120	140	80	120	120	160	160	200	200	260	260	330
140	160	90	130	130	180	180	230	230	300	300	380
160	180	100	140	140	200	200	260	260	340	340	430
180	200	110	160	160	220	220	290	290	370	370	470
200	225	120	180	180	250	250	320	320	410	410	520
225	250	140	200	200	270	270	350	350	450	450	570
250	280	150	220	220	300	300	390	390	490	490	620
280	315	170	240	240	330	330	430	430	540	540	680
315	355	190	270	270	360	360	470	470	590	590	740
355	400	210	300	300	400	400	520	520	650	650	820
400	450	230	330	330	440	440	570	570	720	720	910
450	500	260	370	370	490	490	630	630	790	790	1000
500	560	290	410	410	540	540	680	680	870	870	1100
560	630	320	460	460	600	600	760	760	980	980	1230
630	710	350	510	510	670	670	850	850	1090	1090	1360
710	800	390	570	570	750	750	960	960	1220	1220	1500
800	900	440	640	640	840	840	1070	1070	1370	1370	1690
900	1000	490	710	710	930	930	1190	1190	1520	1520	1860
1000	1120	530	770	770	1030	1030	1300	1300	1670	-	-
1120	1250	570	830	830	1120	1120	1420	1420	1830	-	-
1250	1400	620	910	910	1230	1230	1560	1560	2000	-	-

Bearing Cages

The bearing cage is the component in a bearing that separates the balls/rollers, maintains the rolling element's symmetrical radial spacing and usually holds the bearing together.

Bearing cages are guided by one of the available surfaces between the inner and outer rings.

The primary purpose of a cage is:

- Holds the rolling elements apart in order to avoid their contact and reduce the frictional moment and frictional heat
- Holds the rolling elements in equal distance to optimise load distribution
- Guides the rolling elements in the unloaded zone
- Retains the rolling elements when one bearing ring is removed during mounting or dismounting.

CAGES CAN BE CLASSIFIED ACCORDING TO THE MANUFACTURING PROCESS AND MATERIAL:

- Pressed cages that use cold-rolled steel
- Machined cages that use high tensile strength brass casting or carbon steels
- Polyamide cages that use polyamide resins

MATERIAL IS SELECTED ACCORDING TO THE OPERATING CONDITIONS. EXAMPLE:

- Polyamide cages should only be used in the temperature range of -40° to $+120^{\circ}\text{C}$
- Brass cages should not be used in environments with ammonia or at temperatures over 300°C

Both the design and material of the cage have a significant influence on the suitability of a rolling bearing for a particular application.

Type	Bearing	Cages		
		Synthetic material	Pressed steel	Machined solid
Ball bearings				
Cylindrical roller bearings				
Tapered roller bearings				/
Double-row spherical roller bearing				
Needle roller bearings				/
Ball thrust bearing		/		/
Spherical roller thrust bearing		/		/

SEALS FOR BEARINGS

Seals for bearing are used to prevent solid contaminants and moisture from penetrating into the bearing and at the same time to retain the lubricant in the bearing or bearing arrangement. They should have a minimum of friction and produce minimum wear while maintaining their efficiency even under the most unfavourable operating conditions, so that bearing performance and life are not affected.

Many factors have to be considered when selecting the most suitable sealing for a particular bearing arrangement: the type of lubrication (oil or grease), the peripheral speed at the sealing surface, the shaft arrangement (horizontal or vertical) and possible shaft misalignment, the space available, the friction in the seal and the temperature increase resulting from it, environmental influences, justifiable costs, etc.

The selection should be maintained carefully, considering the operating conditions, the cost of the seal and total effects included (costs of replacement of a bearing should be taken into account as well).

Types of sealing

NON-CONTACT SEALING

The effectiveness of non-contact seals depends in principle on the sealing action of narrow gaps between rotating and stationary components. The gaps may be arranged radially, axially or axially and radially in combination. Non-contact seals have practically no friction and do not wear. They are generally not easily damaged by solid contaminants. They are particularly suitable for high speeds and high temperatures. Their sealing efficiency may be enhanced by pressing grease into the gaps.

CONTACT SEALS

The action of contact seals depends on the seal exerting a certain pressure at the seal/sealing contact area, usually by a sealing lip or surface, which is relatively narrow. The penetration of solid contaminants or moisture and /or the loss of lubricant are thus prevented.

The pressure may be produced either by the resilience of the sealing material and the designed interference between the seal and the sealing surface or from the force exerted by a garter spring incorporated in the seal.

Contact seals generally provide very reliable sealing, particularly when wear is kept to a minimum by producing an appropriate surface quality on the sealing surface and by lubricating the seal lip. The friction of the seal on the sealing surface and the rise in temperature that it generates are a disad-

vantage, and contact seals are therefore only useful up to certain peripheral speeds. They are also susceptible to mechanical damage, for example because of improper mounting or by solid contaminants.

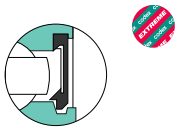
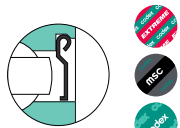
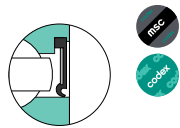
Seal device			
Suffix	RS, 2RS	Z, ZZ	RS, 2RS
Application	Deep groove ball bearings, double row angular contact ball bearings		

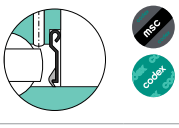
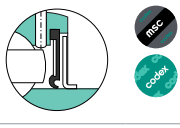
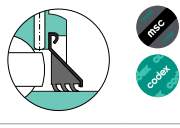
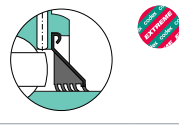
Seal device				
Suffix	K (omit - SA and SB type)	B (omit - HC and UC type)	L3	L5
Application	Bearing inserts, special bearings			

*Other options available on request

Assembly and disassembly of bearings

Proper assembly requires professionalism and care, cleanliness and precision as well as the correct tools.



Bearings are very important machine component parts that require high accuracy to do their job properly. It is very important that assembly is performed by qualified and well-equipped workers.

There is one rule that must apply: mounting and dismounting forces should not be transferred over roller units and raceway. Bearings will only function properly if mounted correctly.

MOUNTING ON SHAFT

Bearings with cylindrical bores are usually mounted by pressing them on the shafts (press fit) or heating them to expand their diameter (shrink fit). The seating surface on the shaft should be lightly oiled before mounting. The bearing can be driven into position by applying light hammer blows through a rubber-made inserted piece. If heating is used, temperatures should not be higher than 125°C and necessary temperature differences can be determined using the bearing and shaft (housing) measurements in diagram X.

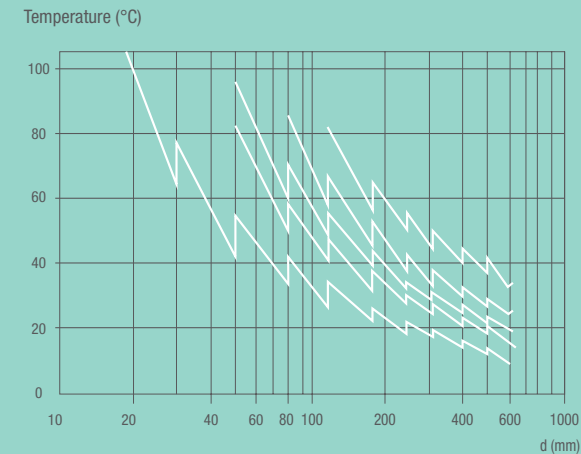

Necessary temperatures for bearing mounting

MOUNTING BEARINGS WITH TAPERED BORE

Bearings with tapered bores can be mounted directly on to tapered shafts or cylindrical shafts using tapered sleeves and an axial locking device (shaft nut, end cover). Fitting does not depend on the size of the bore and shaft but the **length that the bearing is pulled onto the tapered seating**. Bearing clearance is reduced that way.

MOUNTING IN HOUSING

Bearing housings are assemblies designed to make it easy to install bearings and shafts, while protecting bearings, extending their operating life and simplifying maintenance. These units are designed for self-aligning ball bearings, spherical roller bearings and CARB toroidal roller bearings.

Housed bearings provide shaft support for radial, thrust or a combination of loads. Mounted bearing types include pillow blocks (solid or split), flanged cartridges, cylindrical cartridges and take-up units.

Recommended fits

The tolerances of the bore and outside diameter of rolling bearings are internationally standardised.

The following factors should be considered: conditions of rotation, magnitude

of the load, bearing internal clearance, temperature conditions, running accuracy requirements, design and materials of **seatings**, ease of mounting and dismounting, displacement of the non-locating bearing.

TOLERANCE CLASSIFICATIONS

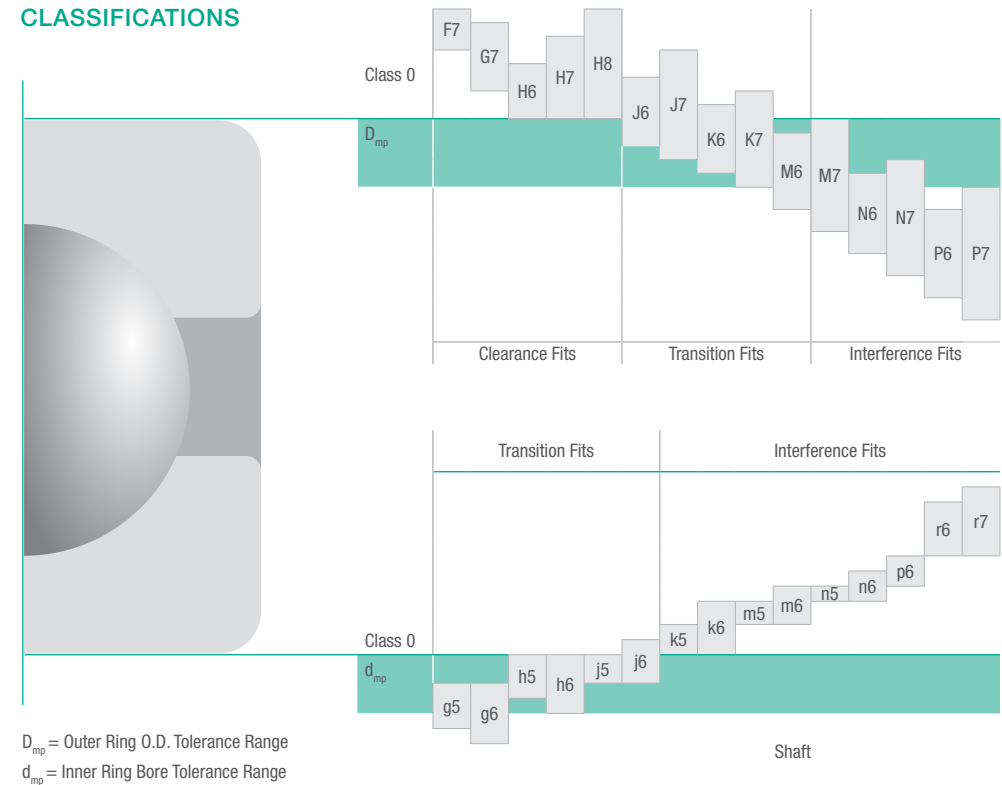

Dismounting

If you plan to re-use bearings after removal, the dismounting forces should not impact roller units and the raceway of the bearing.

Smaller bearings can be dismounted with light hammer strokes through a rubber-made inserted piece on the ring face. It is better to work using tools for dismounting process, screws, induction heaters or slotted rings.

Bearings with a tapered bore can be removed by loosening the sleeve nut and then using a hammer and tubular insert. Larger bearings with a tapered bore should be dismounted using hydraulics.



Bearing maintenance

Lubrication

This information relates to bearings without integral seals or shields. CODEX bearings and bearing units with integral seals and shields are supplied to the customer pre-greased. Standard greases used by CODEX have different temperature ranges and other properties to fit the intended application areas and filling grades appropriate to the bearing size. Codex sealed bearings are generally filled with lithium grease (NLGI consistency 2, temp. range from -20 up to $+120^{\circ}\text{C}$)

Grease lubrication

Roughly 9/10 of all bearings are lubricated with grease. The main advantage of grease over oil is that it is more easily retained in the bearing. However, lower speeds are possible with greased bearings than with oil lubrication. Where bearings are used at very low speeds and must be well protected against corrosion, it is recommended to fill the bearing housing completely with grease.

Lubricating greases consist of a mineral or synthetic oil combined with a thickener. The thickeners are usually metallic soaps. To enhance certain properties of the greases, different additives can be used.

The most important factors to consider when selecting grease are: Viscosity of the base oil, the consistency, operating temperature range and load carrying ability. Different operating conditions require different lubricants, relubrication intervals and lubricant change intervals. For special requirements, other greases can be supplied to customer on demand.

Inspection and cleaning of bearing arrangement

Bearing arrangements should be inspected and cleaned regularly. Between detailed inspections of the entire machinery, noisiness and lubricants are controlled and temperature is measured. Frequency depends on the application type.

After an arrangement is cleaned and washed (by using correct cleaner), it should be well dried and oiled or greased in order to prevent corrosion.

Bearing storage

If bearings are stored in their original packaging, they are protected against corrosion for several years. Storage room humidity should not exceed 60%.

Lubricant deteriorates over time as a result of aging, condensation and separation of the oil and thickener. If sealed bearings are kept in the storeroom for a longer time, grease can solidify. After mounting, such bearings will have a higher moment of friction. This should be taken into consideration.

Bearing failure

Bearings are among the most important components in the vast majority of machines. 90% of bearings outlive the equipment in which they are installed. Despite careful design and manufacturing processes, it sometimes happens that bearings do not reach their required service life. Each type of failure leaves its own special imprint on the bearing. By examining failed bearings, it is possible to determine the root cause and define corrective actions to prevent a reoccurrence.

EXCESSIVE PRELOAD OR OVERLOAD

Excessive loads usually cause premature fatigue. The solution is to use a bearing with greater capacity or reduce load.

OVERHEATING

Discoloration of cages, rolling elements and raceway rings is the symptom of bearing overheating. This results in reduced bearing hardness and early failure. Required are thermal or overload controls and supplemental cooling.

CAGE DAMAGE

Improperly installed or dropped bearing. Bearing handling needs to be improved.

FALSE BRINELLING

Elliptical wear marks in axial direction at each ball position with a bright finish indicate excessive external vibration. Problem is corrected by isolating bearings from external vibration.

TRUE BRINELLING

Occurs when loads exceed the elastic limits of the ring material. Marks show as indentations in the raceway. Caused by improper bearing installation. Proper assembly requires professionalism and care, cleanliness and precision as well as the correct tools.

TIGHT FITS

Discoloured, wide ball path at bottom of raceway indicates a tight fit. Where interference fit exceeds the radial clearance, balls will become over-loaded. Increased radial clearance or other corrective actions are required.

IMPROPER FIT

Loose fits can cause relative motion between mating parts. If fit is improper, fretting occurs. This refers to wear and sometimes corrosion damage on mounting surfaces. Check recommended fits to avoid this problem.

PEELING

Dull or cloudy spots appear on surface. From such dull spots, tiny cracks are generated. Due to thin lubricant film from high loads/low RPM or elevated temperatures. Improvement of surface finish of the rolling mating or proper lubricant selection is recommended.

CORROSION / ETCHING

Rusting and pitting caused by moisture or water exposure are red/brown areas on bearing parts. If bearings are used in hostile environment, solutions like external seals, stainless steel, surface treatments should be considered.

FOREIGN MATERIAL

Contamination is one of the most common causes of bearing failure. Large particles can get imbedded into soft cage, fine abrasive particle contamination or contamination from other fatigued parts is caused by inadequate sealing or poor maintenance. Proper assembly requires clean work areas, tools and fixtures.

NORMAL FATIGUE FAILURE

Fatigue failure is the fracture of the running surfaces. This type of failure will always be accompanied by increased vibration. Replacement of the bearing is required or redesign to use a bearing with longer calculated fatigue life.

MISALIGNMENT

Raceway ball track not parallel to raceway edges are caused by inaccurate machining or wear of bearing seats. Appropriate corrective actions are shaft and housing inspection and using precision grade locknuts.

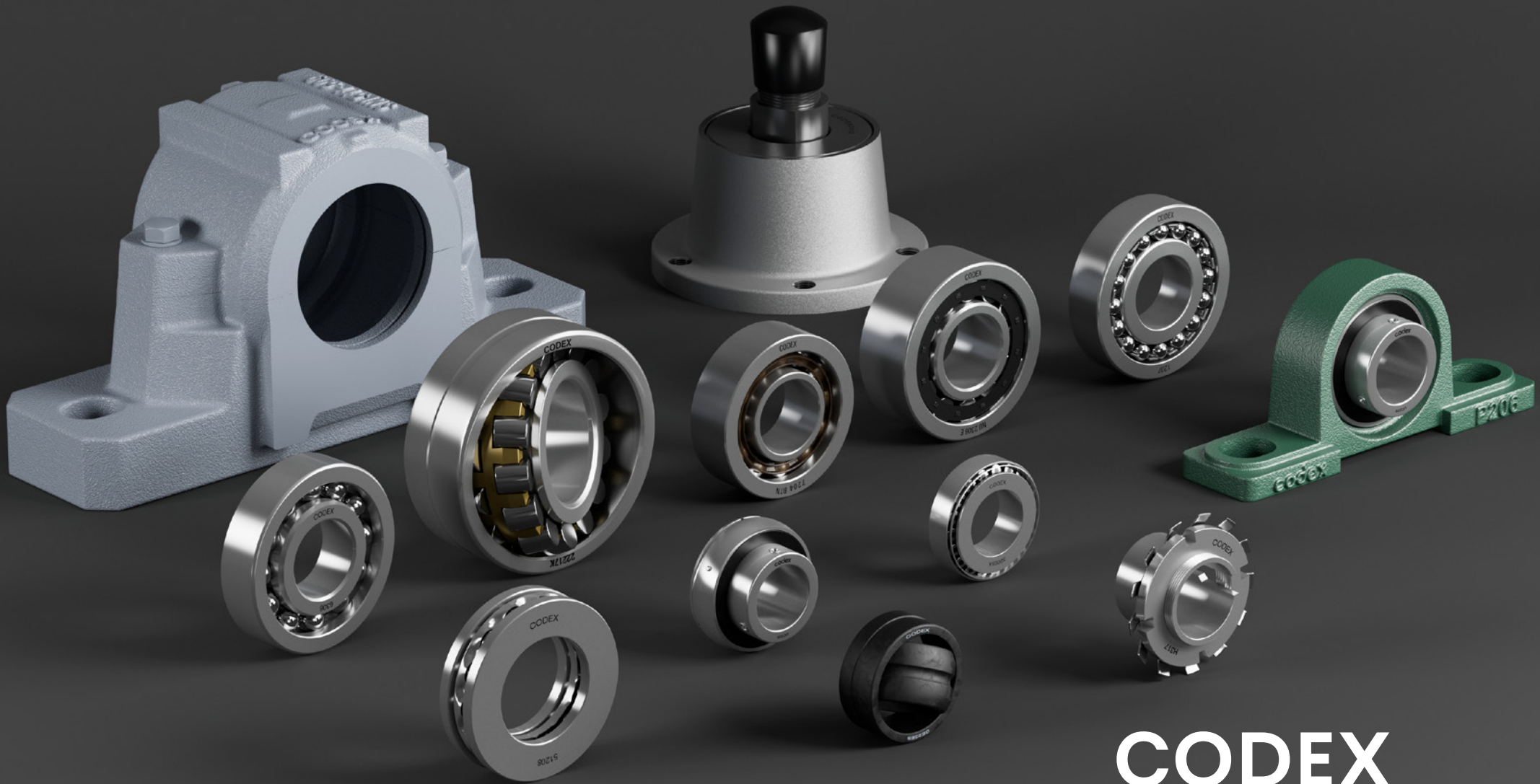

CODEX PRODUCT RANGE



Deep groove ball bearings

Deep groove ball bearings are the most widely used bearing type and are particularly versatile. Deep groove ball bearings are the most widely used bearing type and are particularly versatile. This makes them the most popular of all bearing types.

Deep groove ball bearings are capable of carrying loads in either direction, with relatively higher radial load carrying capacity, and are suitable for low or medium load applications. Depending on the type and precision of the selected bearing, they can be used for low, medium or even high-speed applications. Also, they are well suited for applications that require high running accuracy and low noise and low torque applications.

CODEX deep groove ball bearings are available in a wide range, as defined by the ISO standard. They can also be made according to special dimensional requirements but within some design limitations. We can also offer them in Stainless Steel material. Standard cage material is steel sheet.

NOMENCLATURE:

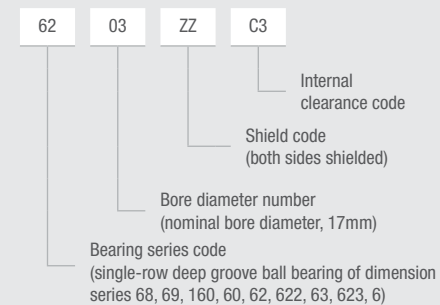

INTERNAL CLEARANCE CODE:

- C2** Less than standard clearance
- CN** Normal clearance. No symbol. Standard if not otherwise indicated.
- C3** Greater than standard clearance
- C4** Greater clearance than C3
- C5** Greater clearance than C

PREFIX/SUFFIX:

- N** snap ring groove on outer ring
- NR** snap ring groove on outer ring, snap ring included
- SS** stainless steel material
- TN** Polyamide cage
- M** brass cage

SHIELD CODE:

- No symbol** Open type
- Z** non-contact single side steel shield
- ZZ** non-contact double side steel shield
- RS** one side rubber seal
- 2RS** double side rubber seal

CODEX BASIC TYPES & SERIES

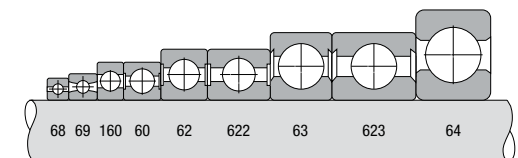

Single row deep groove ball bearings

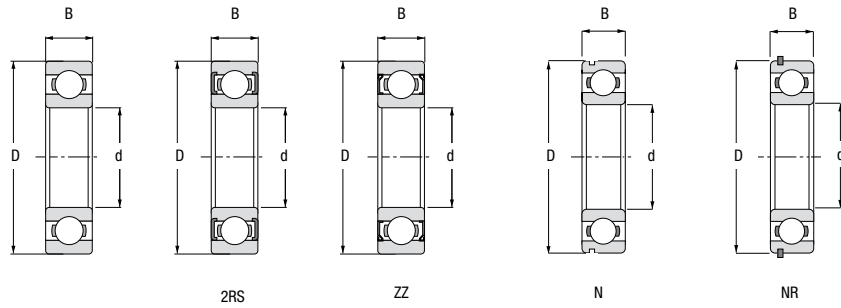

Main dimensions (mm)			Load ratings (kN)		Limiting speeds * (rpm)	Weight (kg)	Designation
d	D	B	Dynamic (Cr)	Static (Cor)			
3	10	4	0,48	0,146	52000	0,002	623
	7	3	0,24	0,1	60000	0,001	683
	8	4	0,43	0,1	65000	0,001	693
4	13	5	1,01	0,49	67000	0,003	624
	16	5	1,03	0,49	60000	0,005	634
	9	4	0,49	0,22	75000	0,002	684
5	11	4	1,2	0,35	54000	0,002	694
	14	5	1,02	0,49	46000	0,003	605
	16	5	1,34	0,67	55000	0,005	625
	19	6	1,82	0,92	50000	0,009	635
6	11	5	0,55	0,25	45000	0,002	685
	13	4	1	0,35	50000	0,002	695
	17	6	1,73	0,77	43000	0,005	606
	19	6	2,15	0,85	49000	0,008	626
	22	7	1,99	0,78	48000	0,012	636
7	13	5	0,96	0,4	55000	0,003	686
	15	5	1,55	0,61	32000	0,004	696
	19	6	2,2	0,94	40000	0,008	607
	22	7	1,99	0,78	45000	0,012	627
	26	9	3,9	1,95	32000	0,023	637
8	14	3,5	0,91	0,45	45000	0,002	687
	17	5	1,24	0,64	42000	0,006	697
	22	7	3,36	1,37	32000	0,012	608
	24	8	3,85	1,65	32000	0,018	628
	28	9	3,9	1,96	45000	0,027	638
9	16	5	0,97	0,5	36000	0,004	688
	19	6	2,13	0,88	33000	0,008	698

Main dimensions (mm)			Load ratings (kN)		Limiting speeds * (rpm)	Weight (kg)	Designation
d	D	B	Dynamic (Cr)	Static (Cor)			
9	24	7	3,8	1,63	36000	0,014	609
	26	8	4,65	1,9	38000	0,02	629
	30	10	4,9	2,3	24000	0,033	639
	17	5	1,25	0,6	33000	0,003	689
	20	6	1,72	0,95	25000	0,008	699
10	19	5	1,71	0,84	22000	0,005	6800
	22	6	3,2	1,47	21000	0,01	6900
	26	7	5,11	2,38	22000	0,019	16000
	26	8	4,62	1,96	30000	0,02	6000
	26	12	4,58	1,96	19000	0,025	63000
	30	9	5,07	2,36	32000	0,031	6200
	30	14	4,9	2,25	17000	0,04	62200
	35	11	8,06	3,4	31000	0,054	6300
	35	17	8,06	3,4	15000	0,06	62300
	21	5	1,91	1,04	29000	0,006	6801
12	24	6	2,89	1,46	27000	0,011	6901
	28	7	5,1	2,4	26000	0,023	16001
	28	8	5,1	2,38	27000	0,022	6001
	28	12	5,02	2,32	17000	0,029	63001
	32	10	6,82	3,05	22000	0,032	6201
	32	14	6,85	3,1	15000	0,048	62201
	37	12	9,72	5,08	19000	0,061	6301
	37	17	9,75	4,15	14000	0,07	62301
	24	5	2,07	1,25	26000	0,007	6802
	28	7	4,31	2,25	24000	0,017	6902
15	32	8	5,59	2,84	22000	0,025	16002
	32	9	5,58	2,85	23000	0,031	6002
	32	13	5,48	2,8	14000	0,039	63002
	35	11	7,65	3,72	19000	0,045	6202
	35	14	7,8	3,75	13000	0,054	62202
	42	13	11,5	5,42	17000	0,08	6302
	42	17	11,4	5,4	12000	0,11	62302
	26	5	3,48	2,23	21000	0,019	6803
	30	7	4,59	2,55	22000	0,018	6903
	35	8	6,8	3,25	24000	0,032	16003
17	35	10	6	3,25	20000	0,04	6003
	35	14	6,05	3,25	13000	0,052	63003
	40	12	9,58	4,78	17000	0,064	6203
	40	16	9,55	4,75	12000	0,089	62203
	47	14	13,5	6,58	15000	0,109	6303
	47	19	13,3	6,55	11000	0,16	62303
	62	17	22,9	10,8	18000	0,27	6403
	32	7	3,48	2,23	21000	0,019	6804
	37	9	6,37	3,68	19000	0,036	6904
	20	42	8	7,91	4,44	18000	0,051
42		12	10	5,85	15000	0,078	6004

Main dimensions (mm)			Load ratings (kN)		Limiting speeds * (rpm)	Weight (kg)	Designation
d	D	B	Dynamic (Cr)	Static (Cor)			
20	42	16	9,36	5	11000	0,086	63004
	47	14	12,8	6,65	14000	0,103	6204
	47	18	12,7	6,5	10000	0,13	62204
	52	15	15,8	1,88	13000	0,142	6304
	52	21	15,8	7,75	9500	0,21	62304
	72	19	30,5	14,5	15000	0,41	6404
25	37	7	3,68	2,63	18000	0,022	6805
	42	9	6,66	4,18	16000	0,041	6905
	47	8	8,35	5,1	15000	0,06	16005
	47	12	10	5,85	15000	0,078	6005
	47	16	11,2	6,55	9500	0,11	63005
	52	15	14	7,88	12000	0,127	6205
	52	18	14	7,8	8500	0,15	62205
	62	17	22,2	11,5	11000	0,219	6305
	62	24	22,5	11,6	75000	0,326	62305
	80	21	35,8	19,3	8500	0,53	6405
30	42	7	4	3,15	15000	0,026	6806
	47	9	7,24	5,01	14000	0,045	6906
	55	9	9,95	6,53	13000	0,091	16006
	55	13	13,2	8,3	12000	0,11	6006
	55	19	13,3	8,3	8000	0,17	63006
	62	16	19,5	11,5	10000	0,202	6206
	62	20	16,5	11,2	7500	0,243	62206
	72	19	27	15,2	9200	0,349	6306
	72	27	22,5	11,6	7500	0,326	62306
	90	23	43,6	23,6	7500	0,74	6406
35	47	7	4,27	3,6	13000	0,029	6807
	55	10	10,39	7,16	12000	0,073	6907
	62	9	10,82	7,83	12000	0,11	16007
	62	14	16,2	10,5	11000	0,148	6007
	62	20	15,9	10,2	7000	0,22	63007
	72	17	25,5	15,2	9000	0,29	6207
	72	23	25,5	15,3	6300	0,388	62207
	80	21	33,2	19,2	8400	0,455	6307
	80	31	33,2	19	6000	0,89	62307
	100	25	55,3	31	6700	0,95	6407
40	52	7	4,41	3,89	12000	0,033	6808
	62	12	13,02	9,2	11000	0,112	6908
	68	9	12,6	7,65	10000	0,125	16008
	68	15	17,2	11,8	9500	0,185	6008
	68	21	16,6	10,5	6300	0,27	63008
	80	18	29,5	18	8200	0,368	6208
	80	23	30,7	19	5600	0,471	62208
	90	23	40,8	24	7500	0,639	6308
	90	33	41	24	5000	0,89	62308
	110	27	63,7	36,5	6000	1,25	6408

Main dimensions (mm)			Load ratings (kN)		Limiting speeds * (rpm)	Weight (kg)	Designation	
d	D	B	Dynamic (Cr)	Static (Cor)				
45	58	7	6,4	5,65	11000	0,04	6809	
	68	12	13,49	10,3	9800	0,132	6909	
	75	10	12,9	10,5	9200	0,171	16009	
	75	16	21	14,8	8800	0,23	6009	
	75	23	14	20	5500	0,36	63009	
	85	19	32,5	20,5	7600	0,416	6209	
	85	23	33,2	24,6	5000	0,523	62209	
	100	25	52,8	31,8	6700	0,83	6309	
	100	36	52,7	31,5	4500	1,19	62309	
	120	29	76,1	45	5300	1,55	6409	
	50	65	7	6,61	6,08	9000	0,052	6810
		72	12	13,9	10,99	8900	0,133	6910
		80	10	13,2	11,3	8400	0,18	16010
		80	16	22	16,2	8300	0,258	6010
80		23	21,6	15,6	5000	0,37	63010	
90		20	35	23,2	7000	0,463	6210	
90		23	35,1	23,2	4800	0,55	62210	
110		27	61,8	37,9	6200	1,082	6310	
110		40	61,8	38	4300	1,5	62310	
130		31	87,1	52	5000	1,9	6410	
55		72	9	8,32	6,2	8500	0,083	6811
		80	13	15,9	11,4	8000	0,19	6911
		90	11	19,5	14	7500	0,26	16011
		90	18	28,1	21,2	7500	0,39	6011
	100	21	46,3	29	6300	0,61	6211	
	100	25	43,6	29	4300	0,7	62211	
	120	29	44	73,5	6000	1,37	6311	
	120	43	71,5	45	3800	1,95	62311	
	140	33	99,5	65	3000	2,3	6411	
	60	78	10	8,71	6,7	7500	0,11	6812
		85	13	16,5	12	7500	0,2	6912
		95	11	19,9	15	6700	0,283	16012
		95	18	29,6	23,2	6700	0,42	6012
		110	22	47,5	32,5	6000	0,78	6212
110		28	47,5	32,5	4000	0,97	62212	
130		31	81,5	52,1	5300	1,72	6312	
130		46	82	52	3400	2,5	62312	
150		35	99,5	65	3000	2,75	6412	
65		85	10	12,4	12,7	7000	0,13	6813
		90	13	17,4	16	6700	0,22	6913
		100	11	21,2	16,5	6500	0,3	16013
		100	18	30,5	25,1	6300	0,44	6013
		120	23	57	40,2	5300	1	6213
	120	31	55,9	40,5	3600	1,25	62213	
	140	33	92,6	59,6	5000	2,1	6313	
	140	48	92,3	60	3200	3	62313	
	160	37	118	78	4500	3,28	6413	

Main dimensions (mm)			Load ratings (kN)		Limiting speeds * (rpm)	Weight (kg)	Designation
d	D	B	Dynamic (Cr)	Static (Cor)			
70	90	10	12,4	13,2	7000	0,14	6814
	100	16	21,2	25,7	6200	0,35	6914
	110	13	27,8	25	6000	0,43	16014
	110	20	37,9	31	6000	0,61	6014
	125	24	62	43,8	5300	1,09	6214
	125	31	60,5	45	3400	1,3	62214
	150	35	104	63,1	4900	2,55	6314
	150	51	104	68	3000	3,55	62314
	180	42	143	104	4500	4,93	6414
75	95	10	12,7	14,3	6600	0,16	6815
	105	16	22,6	30,5	6200	0,36	6915
	115	13	27,5	25	6000	0,43	16015
	115	20	41,6	33,5	5300	0,65	6015
	130	25	66,17	50	5000	1,19	6215
	130	31	66	49,5	3200	1,4	62215
	160	37	114	76,5	4500	3,06	6315
80	100	10	13	15	5600	0,17	6816
	110	16	26,1	20,5	5400	0,38	6916
	125	14	35,1	31,5	5600	0,61	16016
	125	22	47,5	40	5000	0,87	6016
	140	26	72,2	53,1	4700	1,47	6216
	140	33	72,5	53	4500	1,9	62216
	170	39	122,8	86,2	4200	3,63	6316
	200	48	163,5	125	4400	6,86	6416
85	110	13	19,5	20,8	5300	0,27	6817
	120	18	32	30	5100	0,55	6917
	130	14	35,8	33,5	5000	0,64	16017
	130	22	49,7	42,6	4700	0,91	6017
	150	28	83,3	63,6	4400	1,8	6217
	150	36	83,5	64	4200	2,6	62217
	180	41	132,5	96	3800	4,25	6317
	210	52	174	137	4200	9,5	6417
90	115	13	19,5	22	5300	0,31	6818
	125	18	33,2	31	4800	0,59	6918
	140	16	43,6	39	4800	0,85	16018
	140	24	58,4	49,2	4500	1,15	6018
	160	30	101	73,5	4000	2,22	6218
	160	40	96	71,5	4000	2,9	62218
	190	43	144	108	3500	4,97	6318
	225	54	186	150	4100	9,78	6418
95	120	13	19,9	22,8	5000	0,3	6819
	130	18	33,8	33,5	4600	0,61	6919
	145	16	44,9	41,5	4200	0,89	16019
	145	24	60,7	54	4200	1,24	6019
	170	32	108	81	4000	2,63	6219
	170	43	109	82	3700	3,3	62219
	200	45	152,4	117,3	3300	5,75	6319

Main dimensions (mm)			Load ratings (kN)		Limiting speeds * (rpm)	Weight (kg)	Designation	
d	D	B	Dynamic (Cr)	Static (Cor)				
100	125	13	17,8	18,3	4800	0,31	6820	
	140	20	42,3	41	4500	0,83	6920	
	150	16	46,2	44	4000	0,94	16020	
	150	24	60	54	4200	1,26	6020	
	180	34	123	92,6	4000	3,18	6220	
	180	46	122	93	3500	3,6	62220	
	215	47	174	141	3200	7,3	6320	
	105	130	13	19,8	22	4500	0,32	6821
145		20	44,3	41	4300	0,87	6921	
160		18	57,5	50,5	4000	1,19	16021	
160		26	72,2	65,5	4000	1,6	6021	
190		36	132,9	104,8	3500	3,79	6221	
110	225	49	182	153	3100	8,18	6321	
	140	16	28,1	26	4300	0,49	6822	
	150	20	43,6	45	4100	0,9	6922	
	170	19	57,6	56,2	3800	1,47	16022	
	170	28	85,2	73,5	3800	1,97	6022	
	200	38	144	118	3200	4,45	6222	
	240	50	203	180	2800	9,66	6322	
120	150	16	29,1	28	4000	0,61	6824	
	165	22	52	54,5	3800	1,21	6924	
	180	19	61	63,1	3300	1,57	16024	
	180	28	85	80	3300	2,1	6024	
	215	40	144	118	3000	5,27	6224	
	260	55	208	186	2800	12,7	6324	
	130	165	18	37,7	43	3600	0,93	6826
180		24	65	67	3400	1,86	6926	
200		22	83,2	81,5	3300	2,36	16026	
200		33	112	100	3300	3,28	6026	
230		40	153	132	2800	5,86	6226	
280		58	229	216	2800	15,15	6326	
140		175	18	39	46,5	3400	1,15	6828
		190	24	89,3	73,5	3200	1,98	6928
	210	22	80,6	86,5	3000	2,52	16028	
	210	33	111	108	3000	3,45	6028	
	250	42	165	150	2500	7,77	6228	
150	300	62	251	245	2700	21,1	6328	
	190	20	48,8	58,5	3200	1,4	6830	
	210	28	90	110,3	2900	3,05	6930	
	225	24	92,2	95	2800	3,14	16030	
	225	35	125	125	2800	4,29	6030	
	270	45	190	181	2200	10,1	6230	
	320	65	276	285	2600	22,91	6330	
160	200	20	52,6	64	3000	1,45	6832	
	240	25	99,5	108	2500	3,66	16032	
	240	38	142	142	2500	6,02	6032	
	290	48	186	186	2000	12,9	6232	
	340	68	276	285	2600	26,2	6332	

Double row deep groove ball bearings

Double row deep groove ball bearings have the same outer diameter and bore diameter as single row ball bearings.

The main difference is that double row ball bearings are slightly wider to fit two rows of balls and that makes them more suitable for applications where load carrying capacity of single row ball bearings is insufficient.

Double-row ball bearings are suitable for medium radial loads and small axial loads in both directions. This type of bearing cannot be used in applications where precise alignment of the rings is not guaranteed.

Other advantages of double row ball bearings are their rigidity and compactness. Standard cage material is steel sheet.

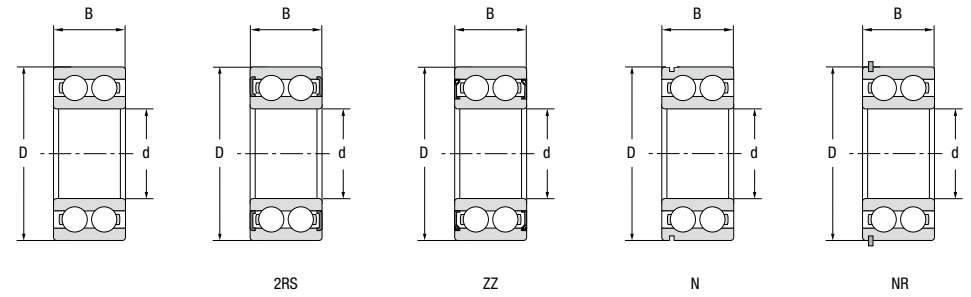

Main dimensions (mm)			Load ratings (kN)		Limiting speeds * (rpm)	Weight (kg)	Designation
d	D	B	Dynamic (Cr)	Static (Cor)			
10	30	14	9,23	5,2	18000	0,049	4200
	35	17	14,3	8,75	17500	0,091	4300
12	32	14	10,4	5,9	18000	0,053	4201
	37	17	11,2	7,8	17000	0,092	4301
15	35	14	11,9	7,3	15000	0,059	4202
	42	17	15,3	9,1	13000	0,12	4302
17	40	16	14,5	9,1	14000	0,09	4203
	47	19	19,5	13,2	13000	0,16	4303
20	47	18	17,8	12,5	9950	0,14	4204
	52	21	23	15,7	9200	0,21	4304
25	52	18	19,3	14,6	9000	0,16	4205
	62	24	31,5	22,4	8000	0,34	4305
30	62	20	26	20,8	7500	0,26	4206
	72	27	40	30	6700	0,5	4306
35	72	23	33	27	6700	0,4	4207
	80	31	50,7	37	6300	0,69	4307
40	80	23	34,5	30,8	6000	0,5	4208
	90	33	63	47,5	5600	0,95	4308
45	85	23	36	33,5	5600	0,54	4209
	100	36	72,5	60	4800	1,25	4309
50	90	23	38	37,5	5000	0,58	4210
	110	40	86,7	70,1	4300	1,7	4310
55	100	25	44	43,5	4600	0,8	4211
	120	43	95,6	85,4	4100	2,15	4311
60	110	28	57	56,4	4100	1,1	4212
	130	46	112,8	101,1	3500	2,65	4312
65	120	31	66,3	65,7	3700	1,45	4213
	140	48	122,6	105	3300	3,25	4313
70	125	31	68,8	72	3900	1,5	4214
	150	51	145,8	114,9	3500	3,95	4314
75	130	31	71,2	78,5	3100	1,6	4215
	160	55	159,8	138	2800	4,8	4315
80	140	33	79	88	3000	2	4216

NOMENCLATURE:

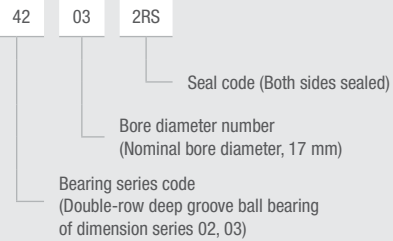

SHIELD CODE:

- No symbol Open type
- ZZ non-contact double side steel shield
- 2RS double side rubber seal

PREFIX/SUFFIX:

- SS stainless steel material
- N snap ring groove on outer ring
- NR snap ring groove on outer ring, snap ring included

CODEX BASIC TYPES & SERIES

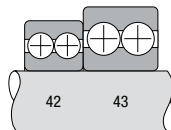

* For applications close to the limiting speeds please contact Codex QA department.

Angular Contact Ball Bearings

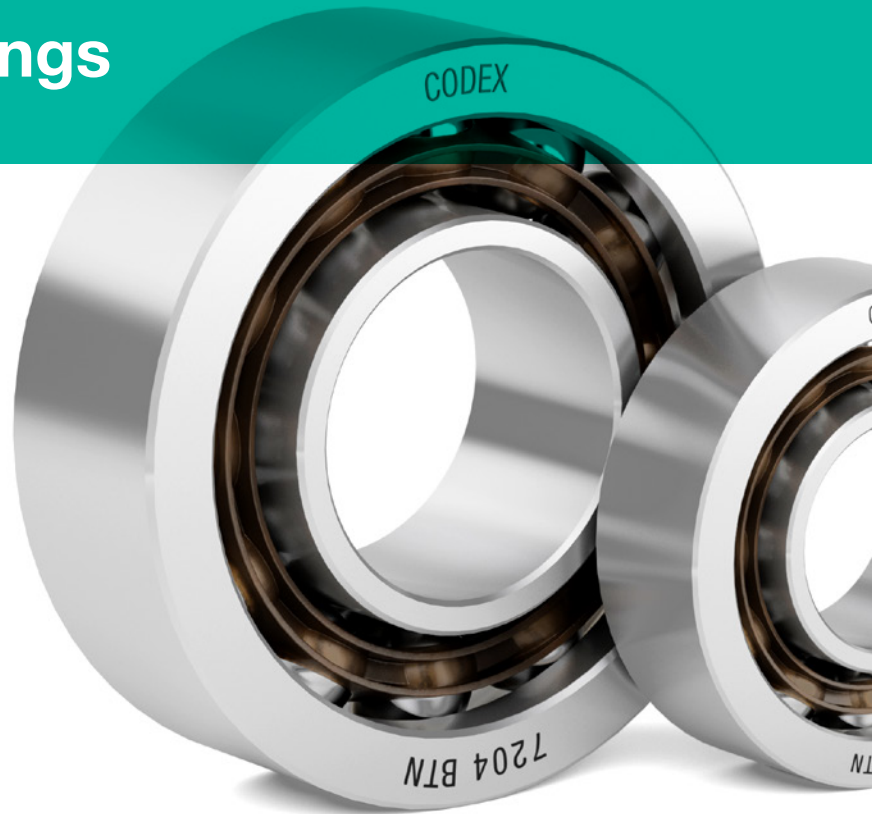

Angular contact ball bearings are similar to deep groove ball bearings but can handle radial and axial loading applications, because the line of contact between the balls and raceway is at an angle in the radial plane. These bearings are suitable for low, medium and high-speed applications.

Single row angular contact ball bearings can accommodate axial loading in only one direction. These ball bearings have one high and low shoulder and are non-separable. Bearings are typically mounted against a second bearing; this gives them very high load capacity. Standard cage material is steel sheet.

There are three different contact angle classifications:

Contact Angle symbol	58-64 HRC
A	25° -30°
B	40°
C	15°

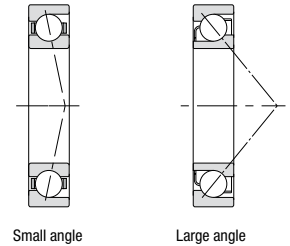

To counteract the axial load, these bearings must be fitted in pairs or more; the options are:

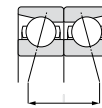

Back to back arrangement

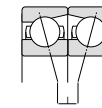

Face to face arrangement

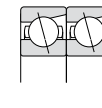

Tandem arrangement

NOMENCLATURE:

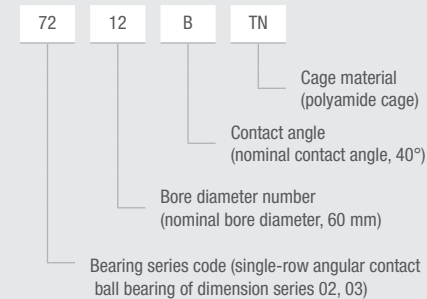

SHIELD CODE:

No symbol Open type
2RS double side rubber seal

PREFIX/SUFFIX:

TN polyamide cage
A Contact angle of 25° -30°
B Contact angle of 40°
C Contact angle of 15°

CODEX BASIC TYPES & SERIES

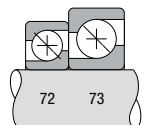

Single row angular contact ball bearings

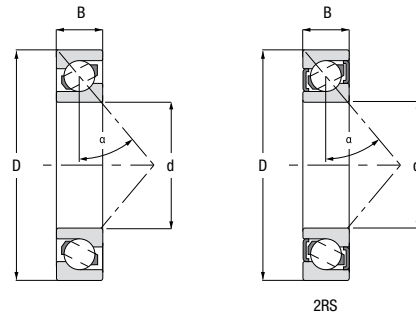

Main dimensions (mm)			Load ratings (kN)		Limiting speeds * (rpm)	Weight (kg)	Designation
d	D	B	Dynamic (Cr)	Static (Cor)			
10	30	9	5.45	2.75	28000	0.029	7200
	35	11	9.5	4.6	22000	0.04	7300
12	32	10	7.2	3.65	24000	0.035	7201
	37	12	10.5	4.95	19000	0.045	7301
15	35	11	8,35	4,35	18000	0,046	7202
	42	13	12,5	6,65	18000	0,057	7302
17	40	12	9,4	5,2	16000	0,069	7203
	47	14	16	8,3	25000	0,121	7303
20	47	14	13,3	7,6	13000	0,11	7204
	52	15	18,5	9,7	23000	0,156	7304
25	52	15	13,9	8,7	15000	0,13	7205
	62	17	22,9	13,3	10000	0,248	7305
30	62	16	19,5	12,6	10000	0,217	7206
	72	19	31	19,5	8700	0,381	7306
35	72	17	28	18,4	11000	0,313	7207
	80	21	36,3	24,3	7700	0,512	7307
40	80	18	32	23,5	7500	0,402	7208
	90	23	41,1	27	7000	0,63	7308
45	85	19	33,2	24	7000	0,46	7209
	100	25	53,8	36,1	6200	0,85	7309
50	90	20	36,5	27,9	6400	0,51	7210
	110	27	66,2	45,6	5600	1,23	7310
55	100	21	45,5	34,8	5800	0,68	7211
	120	29	76,5	58	5000	1,57	7311
60	110	22	54	42,6	5100	1,02	7212
	130	31	83,5	58,6	4600	1,696	7312
65	120	23	62,1	50,8	4800	1,09	7213
	140	33	100,2	76,4	4000	2,38	7313
70	125	24	67,4	53,5	4700	1,18	7214
	150	36	113,3	84	4300	2,89	7314
75	130	25	68	57,8	4300	1,32	7215
	160	37	120,5	96,3	3800	3,47	7315
80	140	26	78	67,4	4000	1,57	7216
	170	39	130,8	105,6	3500	4,13	7316

*For applications close to the limiting speeds please contact Codex QA department.

Double row angular contact ball bearings

Double row angular contact ball bearings have two rows of balls arranged back-to-back. Basically, they correspond to two single row angular contact ball bearings arranged back to back. The main difference is they can take a bi-directional axial load in one bearing, but otherwise it would take a matched pair of bearings.

Standard cage material is steel sheet. Contact angle is 30°.

NOMENCLATURE:

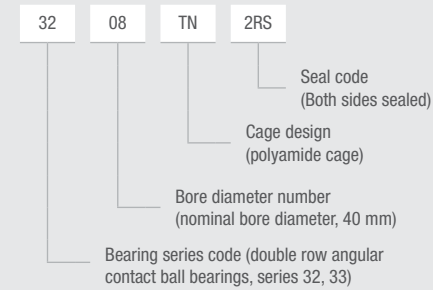

SHIELD CODE:

- No symbol Open type
- ZZ non-contact double side steel shield
- 2RS double side rubber seal

INTERNAL CLEARANCE CODE:

- C2 Less than standard clearance
- CN Normal clearance. No symbol. Standard if not otherwise indicated.
- C3 Greater than standard clearance

PREFIX/SUFFIX:

- TN polyamide cage
- N snap ring groove on outer ring
- NR snap ring groove on outer ring, snap ring included

CODEX BASIC TYPES & SERIES

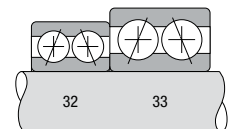

Double row angular contact ball bearing

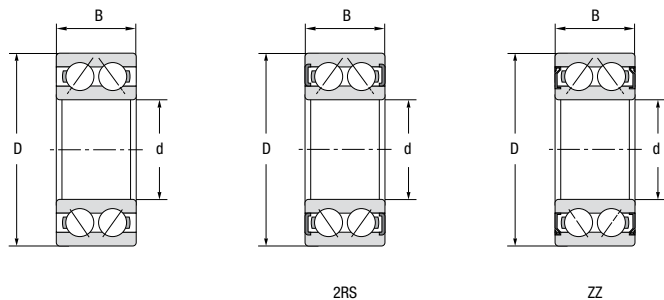

Main dimensions (mm)			Load ratings (kN)		Limiting speeds * (rpm)	Weight (kg)	Designation
d	D	B	Dynamic (Cr)	Static (Cor)			
70	125	39,7	94	83	2900	1,85	3214
	150	63,5	154	125	3100	4,9	3314
75	130	41,3	94	84	2900	2,1	3215
	160	68,3	186	159	2400	5,7	3315
80	140	44,4	109	102	2500	2,65	3216
	/		/	/	/		

* For applications close to the limiting speeds please contact Codex QA department.

Main dimensions (mm)			Load ratings (kN)		Limiting speeds * (rpm)	Weight (kg)	Designation
d	D	B	Dynamic (Cr)	Static (Cor)			
10	30	14,3	7,61	4,3	24000	0,051	3200
12	32	15,9	9,4	5,2	15000	0,058	3201
	37	19	14,6	8,3	14000	0,093	3301
15	35	15,9	9,4	5,2	18000	0,066	3202
	42	19	14,2	8,7	10000	0,13	3302
17	40	17,5	12,75	8,4	10000	0,096	3203
	47	22,2	15,8	10	9500	0,18	3303
20	47	20,6	15,3	10,4	9000	0,16	3204
	52	22,2	22,6	14,7	8500	0,22	3304
25	52	20,6	16,3	12	8000	0,18	3205
	62	25,4	28,9	19,4	7500	0,35	3305
30	62	23,8	28,6	20,6	7000	0,29	3206
	72	30,2	39,5	29,2	6500	0,53	3306
35	72	27	30,5	23,7	6000	0,44	3207
	80	34,9	49,5	35,3	5500	0,73	3307
40	80	30,2	40,2	32,3	5500	0,59	3208
	90	36,5	60,5	44,2	5000	0,95	3308
45	85	30,2	40	32,6	5000	0,63	3209
	100	39,7	66,4	49,6	4500	1,4	3309
50	90	30,2	43,9	39,9	4800	0,66	3210
	110	44,4	78,9	60,1	4000	1,95	3310
55	100	33,3	56,9	47,9	4300	1,05	3211
	120	49,2	92,2	71	3800	2,55	3311
60	110	36,5	59,9	53,6	3800	1,4	3212
	130	54	121,5	95,3	3400	3,25	3312
65	120	38,1	73,5	66,6	3600	1,75	3213
	140	58,7	129,6	103,6	2700	4	3313



Self-aligning ball bearings

Self-aligning bearings have two rows of balls; the outer ring has a spherical raceway and its center of curvature coincides with that of the bearing. This gives the bearing their self-aligning ability, therefore angular misalignment of the shaft relative to the housing is possible. This type is recommended when the alignment of the shaft and housing is difficult or the shaft may bend. The axial load capacity is low but non-sealed self-aligning ball bearings have the lowest friction of any bearing type.

Standard cage material is steel sheet.

NOMENCLATURE:

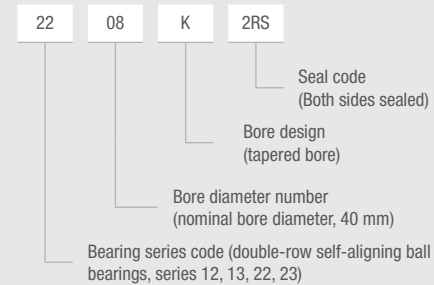

SHIELD CODE:

No symbol Open type
 2RS double side rubber seal

INTERNAL CLEARANCE CODE:

C2 Less than standard clearance
 CN Normal clearance. No symbol. Standard if not otherwise indicated.
 C3 Greater than standard clearance

PREFIX/SUFFIX:

K tapered bore (1:12)
 TN polyamide cage

CODEX BASIC TYPES & SERIES

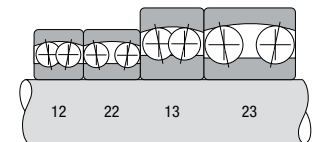

Self-aligning ball bearings

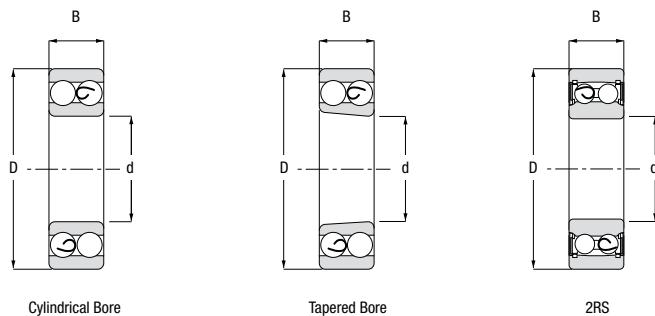

Cylindrical Bore

Tapered Bore

2RS

Main dimensions (mm)			Load ratings (kN)		Limiting speeds * (rpm)	Weight (kg)	Designation	
d	D	B	Dynamic (Cr)	Static (Cor)			Cylindrical Bore	Tapered bore
10	30	9	5,5	1,2	22000	0,033	1200	/
	30	14	7,35	1,5	24000	0,042	2200	/
	35	11	7,25	1,6	20000	0,057	1300	/
	35	17	9,1	2	18000	0,077	2300	/
12	32	10	5,7	1,27	22000	0,039	1201	/
	32	14	7,7	1,7	22000	0,048	2201	/
	37	12	9,6	2,1	18000	0,066	1301	/
	37	17	12,1	2,7	17000	0,082	2301	/
15	35	11	5,7	1,2	22000	0,039	1202	/
	35	14	7,7	1,7	22000	0,048	2202	/
	42	13	9,7	2,1	18000	0,11	1302	/
	42	17	12,1	2,7	17000	0,12	2302	/
17	40	12	8,14	2,03	17000	0,072	1203	/
	40	16	9,9	2,4	16000	0,085	2203	/
	47	14	12,7	3,2	16000	0,13	1303	/
	47	19	14,7	3,5	13000	0,15	2303	/
20	47	14	10,2	2,66	14000	0,12	1204	1204 K
	47	18	12,8	3,3	14000	0,133	2204	2204 K
	52	15	12,6	3,4	12000	0,165	1304	1304 K
	52	21	18,5	4,7	11000	0,193	2304	2304 K
25	52	15	12,2	3,3	12000	0,14	1205	1205 K
	52	18	12,4	3,5	12000	0,15	2205	2205 K
	62	17	18,2	5	10000	0,255	1305	1305 K
	62	24	24,5	6,5	9500	0,319	2305	2305 K
30	62	16	17	4,7	11000	0,2	1206	1206 K
	62	20	16	4,6	11000	0,3	2206	2206 K
	72	19	22	6,3	9400	0,4	1306	1306 K
	72	27	32,5	8,7	8400	0,5	2306	2306 K
35	72	17	19	5,5	8500	0,32	1207	1207 K
	72	23	22,5	7,5	8500	0,38	2207	2207 K
	80	21	30	9,7	7500	0,51	1307	1307 K
	80	31	-	-	7100	0,64	2307	2307 K

Main dimensions (mm)			Load ratings (kN)		Limiting speeds * (rpm)	Weight (kg)	Designation	
d	D	B	Dynamic (Cr)	Static (Cor)			Cylindrical Bore	Tapered bore
40	80	18	19	6	7500	0,42	1208	1208 K
	80	23	22	7,4	7500	0,48	2208	2208 K
	90	23	-	-	6800	0,72	1308	1308 K
	90	33	-	-	6500	0,89	2308	2308 K
45	85	19	23	7,9	7200	0,47	1209	1209 K
	85	23	24	8,5	7200	0,52	2209	2209 K
	100	25	-	-	6500	0,96	1309	1309 K
	100	36	-	-	5800	1,2	2309	2309 K
50	90	20	23,5	8,5	6300	0,53	1210	1210 K
	90	23	24	8,8	6300	0,56	2210	2210 K
	110	27	-	-	5800	1,25	1310	1310 K
	110	40	-	-	5500	1,58	2310	2310 K
55	100	21	27	9,2	6000	0,71	1211	1211 K
	100	25	28	10,5	6000	0,75	2211	2211 K
	120	29	-	-	5500	1,6	1311	1311 K
	120	43	-	-	500	2,03	2311	2311 K
60	110	22	30,5	11,8	5300	0,9	1212	1212 K
	110	28	34,5	12,8	5300	1,03	2212	2212 K
	130	31	-	-	4500	2,03	1312	1312 K
	130	46	-	-	4400	2,57	2312	2312 K
65	120	23	32	12,5	4800	1,15	1213	1213 K
	120	31	44,2	17	4800	1,4	2213	2213 K
	140	33	-	-	4500	2,54	1313	1313 K
	140	48	-	-	4000	3,2	2313	2313 K
70	125	24	35	15,1	4800	1,25	1214	-
	125	31	44	17	4800	1,52	2214	-
	150	35	-	-	4300	3,19	1314	-
	150	51	-	-	4000	3,9	2314	-
75	130	25	39	15,7	4300	1,35	1215	1215 K
	130	31	58,5	19	4300	1,6	2215	2215 K
	160	37	-	-	3800	3,65	1315	1315 K
	160	55	-	-	3500	4,77	2315	2315 K
80	140	26	39,7	17	4000	1,65	1216	1216 K
	140	33	49	20	4000	1,97	2216	2216 K
	170	39	-	-	3800	4,31	1316	1316 K
	170	58	-	-	3500	5,54	2316	2316 K

* For applications close to the limiting speeds please contact Codex QA department.



Tapered roller bearings

Tapered roller bearings are designed to accommodate combined loads, i.e. simultaneously acting in radial and axial loads.

Tapered roller bearings have tapered inner and outer ring raceways and tapered rollers. The projection lines of the raceways meet at a common point on the bearing axis to provide true rolling and low friction. These bearings exist in various designs, including single, double and four row arrangements and in metric and inch series.

Single row tapered roller bearings are detachable. The inner ring with tapered rolls and cage forms one assembly unit, and the outer ring the second. The structure of large numbers of tapered rollers in a single row allows bearings to handle high axial and radial load capacity. Raceway contact areas lay in straight lines, which intersect the bearing axis.

Tapered roller bearings are commonly used for moderate speed, heavy-duty applications where durability is required. Common real-world applications are in agriculture, construction and mining equipment, sports robot combat, axle systems, gear box, engine motors and reducers, propeller shafts, railroad axle-box, differentials, etc.

The main dimensions of metric single row tapered roller bearings conform to standard ISO 355 / DIN 720. Codex tapered roller bearings are manufactured in normal accuracy, however upon request, higher running accuracy bearings can be supplied as well.

Standard cage material is pressed window-type sheet steel.

DESIGNATION

Metric tapered roller bearing designation

NOMENCLATURE:

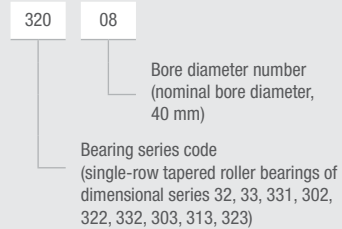

PREFIX/SUFFIX:

TN polyamide cage

CODEX BASIC TYPES & SERIES

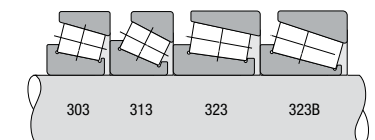
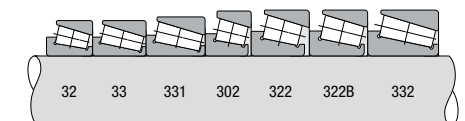

Tapered roller bearings

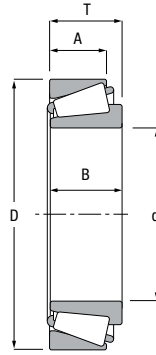

d	Main dimensions (mm)				Load rating (kN)		Limiting speeds * (rpm)	Weight (kg)	Designation
	D	T	B	A	Dynamic C	Static C0			
15	42	14,25	13	11	24,5	20,0	13770	0,095	30302
17	40	13,25	12	11	22,5	18,5	13770	0,075	30203
	47	15,25	14	12	29,8	25,0	12240	0,13	30303
20	47	20,25	19	16	34,7	33,1	12240	0,17	32303
	42	15	15	12	28,8	27,0	12240	0,097	32004
	47	15,25	14	12	28,2	28,0	11475	0,12	30204
	52	16,25	15	13	36,2	32,0	10710	0,17	30304
22	52	22,25	21	18	46,5	45,0	10710	0,23	32304
	44	15	15	11,5	29,9	28,1	11475	0,1	320/22
25	47	15	15	11,5	27,8	32,5	10710	0,11	32005
	52	16,25	15	13	32,9	33,5	9945	0,15	30205
	52	19,25	18	15	36,0	43,3	9945	0,19	32205
	52	19,25	18	16	42,0	44,0	9945	0,19	32205-A
	52	22	22	18	53,4	55,5	9945	0,23	33205
	62	18,25	17	15	46,6	43,0	9180	0,26	30305
	62	18,25	17	13	39,5	40,0	8415	0,26	31305
	62	25,25	24	20	61,7	62,5	9180	0,36	32305
28	52	16	16	12	34,5	38,0	9945	0,15	320/28
	58	17,25	16	14	44,5	41,0	9180	0,25	302/28
	58	20,25	19	16	48,5	48,0	9180	0,25	322/28
30	55	17	17	13	38,8	44,0	9180	0,17	32006
	62	17,25	16	14	42,0	44,0	8415	0,23	30206
	62	21,25	20	17	57,1	56,9	8415	0,28	32206
	62	25	25	19,5	66,4	76,0	8415	0,37	33206
	72	20,75	19	16	57,2	56,0	7650	0,39	30306
	72	20,75	19	17	48,7	50,0	7268	0,39	31306
	72	28,75	27	19,5	81,5	85,0	7650	0,55	32306
32	58	17	17	13	38,5	46,0	8415	0,19	320/32

d	Main dimensions (mm)				Load rating (kN)		Limiting speeds * (rpm)	Weight (kg)	Designation
	D	T	B	A	Dynamic C	Static C0			
35	62	18	18	14	43,3	54,0	8415	0,22	32007
	72	18,25	17	15	55,6	56,0	7268	0,32	30207
	72	24,25	23	19	72,5	78,0	7268	0,43	32207
	72	28	28	22	88,6	105,0	7268	0,56	33207
	80	22,75	21	18	73,1	73,0	6885	0,52	30307
	80	22,75	21	25	63,4	67,0	6503	0,52	31307
40	80	32,75	31	15	102,2	106,0	6885	0,73	32307
	68	19	19	14,5	53,1	71,0	7268	0,27	32008
	75	26	26	20,5	80,2	103,2	6885	0,51	33108
	80	19,75	18	16	62,0	68,0	6503	0,42	30208
	80	24,75	23	19	79,9	86,0	6503	0,53	32208
	80	32	32	25	104,0	131,8	6503	0,77	33208
	90	25,25	23	20	91,5	95,0	6120	0,72	30308
45	90	25,25	23	17	74,5	81,0	5738	0,72	31308
	90	35,25	33	27	110,0	140,0	6120	1	32308
50	75	20	20	15,5	58,5	79,8	6503	0,34	32009
	80	26	26	20,5	85,2	114,0	6120	0,56	33109
	85	20,75	19	16	67,9	76,0	6120	0,48	30209
	85	24,75	23	19	82,5	98,0	6120	0,58	32209
	85	32	32	25	110,0	142,0	5738	0,82	33209
	100	27,25	25	22	110,0	120,0	5355	0,97	30309
	100	27,25	25	18	92,4	102,0	5126	0,95	31309
55	100	38,25	36	30	150,0	170,0	5355	1,35	32309
	80	20	20	15,5	63,5	88,0	6120	0,37	32010
	80	24	24	19	76,7	102,0	6120	0,45	33010
	85	26	26	20	87,0	121,0	5738	0,59	33110
	90	21,75	20	17	77,5	91,0	5738	0,54	30210
	90	24,75	23	19	87,7	100,0	5738	0,61	32210
	90	32	32	24,5	116,0	158,0	5355	0,9	33210
	110	29,25	27	23	134,0	140,0	4820	1,25	30310
	110	29,25	27	19	108,0	120,0	4590	1,2	31310
	110	42,25	40	33	184,5	212,0	4590	1,85	32310
60	90	23	23	17,5	81,5	118,0	5355	0,55	32011
	90	27	27	21	95,0	137,0	5355	0,67	33011
	95	30	30	23	112,0	155,0	5126	0,86	33111
	100	22,75	21	18	94,0	106,0	5126	0,7	30211
	100	26,75	25	21	109,0	128,0	5126	0,83	32211
	100	35	35	27	127,0	188,0	4820	1,2	33211
	120	31,5	29	25	156,0	162,0	4284	1,55	30311
	120	31,5	29	21	123,0	137,0	4284	1,55	31311
65	120	45,5	43	35	222,0	250,0	4284	2,5	32311
	95	27	27	21	96,0	143,0	5126	0,71	33012
	100	30	30	23	114,0	167,0	4820	0,92	33112
	110	23,75	22	19	105,0	114,0	4590	0,88	30212

Main dimensions (mm)					Load rating (kN)		Limiting speeds * (rpm)	Weight (kg)	Designation
d	D	T	B	A	Dynamic C	Static C0			
120	215	43,5	40	34	352,0	465,0	2295	6,15	30224
	215	61,5	58	50	463,0	690,0	2295	9,15	32224
	260	59,5	55	46	578,0	705,0	1989	14	30324
	260	68	62	42	543,0	695,0	1836	15,5	31324
	260	90,5	86	69	825,0	1110,0	1989	21,5	32324
130	180	32	32	25	204,0	360,0	2754	2,4	32926
	200	45	45	34	330,0	540,0	2295	4,95	32026
	230	43,75	40	34	385,0	480,0	2142	7,6	30226
	230	67,75	64	54	542,0	820,0	2142	11,5	32226
	280	63,75	58	49	655,0	795,0	1836	17	30326
140	280	72	66	44	610,0	780,0	1836	18,5	31326
	190	32	32	25	221,0	390,0	2601	2,55	32928
	210	45	45	34	365,0	385,0	2142	5,25	32028
	250	45,75	42	36	425,0	585,0	1989	8,65	30228
	250	71,75	68	58	649,0	1000,0	1989	14,5	32228
150	300	77	70	47	702,0	900,0	1683	24,5	31328
	225	48	48	36	377,0	655,0	1989	6,35	32030
	225	59	59	46	899,0	865,0	1989	8,15	33030
	270	49	45	38	450,0	865,0	1836	11	30230
	270	77	73	60	740,0	1140,0	1836	17,5	32230
160	320	82	75	50	793,0	1000,0	1530	29,5	31330
	240	51	51	38	438,0	780,0	1836	7,75	32032
	290	52	48	40	532,0	735,0	1683	13	30232
	290	84	80	67	890,0	1380,0	1683	25,5	32232
170	340	75	68	58	923,0	1150,0	1530	29	30332
	230	38	38	30	302,0	585,0	2142	4,5	32934
	260	57	57	43	531,0	910,0	1683	10,5	32034
	310	57	52	43	595,0	865,0	1530	19	30234
180	310	91	86	71	990,0	1590,0	1530	28,5	32234
	250	45	45	34	388,0	660,0	1989	6,65	32936
	280	64	64	48	667,0	1160,0	1683	14,5	32036
	320	57	52	43	645,0	815,0	1530	20	30236
190	320	91	86	71	1023,0	1620,0	1454	29,5	32236
	260	45	45	34	305,0	632,0	1836	7	32938
	290	64	64	48	705,0	1200,0	1530	15	32038
200	340	60	55	46	731,0	1000,0	1377	24	30238
	280	51	51	39	425,0	810,0	1683	9,5	32940
	310	70	70	53	760,0	1370,0	1454	19,5	32040
	360	64	58	48	741,0	1120,0	1301	25	30240
220	360	104	98	82	1270,0	2000,0	1301	42,5	32240
	300	51	51	39	525,0	895,0	1530	10	32944
	340	76	76	57	917,0	1630,0	1301	25,5	32044
	400	72	65	54	892,0	1350,0	1224	40	30244
400	114	108	90	1550,0	2550,0	1148	60	32244	

Main dimensions (mm)					Load rating (kN)		Limiting speeds * (rpm)	Weight (kg)	Designation
d	D	T	B	A	Dynamic C	Static C0			
240	320	51	51	39	536,0	980,0	1454	11	32948
	360	76	76	57	941,0	1790,0	1224	27,5	32048
	440	127	120	100	1570,0	3120,0	1071	81,5	32248
	260	400	87	87	65	1150,0	2175,0	1071	40
280	480	137	130	106	2050,0	3350,0	918	105	32252
	380	63,5	63,5	48	773,0	1390,0	1224	20	32956
300	420	87	87	65	1205,0	2290,0	995	40,5	32056
	420	76	76	57	935,0	1950,0	1071	32	32960
	460	100	100	74	1560,0	2950,0	918	58	32060
320	540	149	140	115	2225,0	4130,0	842	140	32260
	440	76	76	57	1060,0	2220,0	995	33,5	32964
480	100	100	74	1580,0	3040,0	842	64	32064	

* For applications close to the limiting speeds please contact Codex QA department.

Cylindrical roller bearings



Cylindrical roller bearings exist in a wide range of designs, series and sizes. Mainly, we distinguish them by the number of roller rows and the inner/outer ring flanges as well as cage designs and materials.

Cylindrical roller bearings are suitable for applications dealing with heavy radial loads and medium to lower speeds. They offer high rigidity, low friction and help to reduce maintenance costs by providing long bearing service life. Having a separable inner or outer ring, they can easily be mounted. Standard cage material is steel sheet.

NOMENCLATURE:

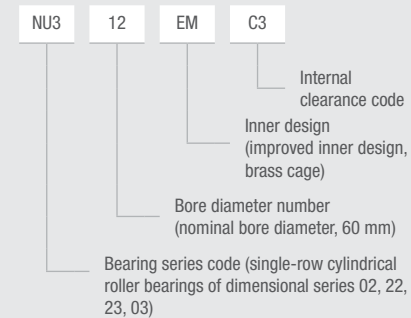

INTERNAL CLEARANCE CODE:

- C2 Less than standard clearance
- CN Normal clearance. No symbol. Standard if not otherwise indicated.
- C3 Greater than standard clearance
- C4 Greater clearance than C3

PREFIX/SUFFIX:

- M Machine solid brass cage
- TN polyamide cage
- E higher load capacity

CODEX BASIC TYPES & SERIES

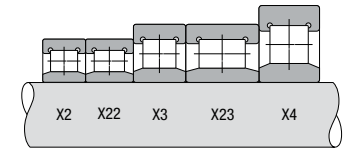

Single Row types – X: N, NJ, NU and NUP

Bearings of NU design

have two integral flanges on the outer ring and a smooth inner ring. Within certain limits, an axial displacement of the shaft in relation to the housing can be accommodated in both directions.

Bearings of NJ design

have two integral flanges on the outer ring and one integral flange on the inner ring. Within certain limits, an axial displacement of the shaft in relation to the housing can be accommodated in one direction.

Bearings of NUP design

have two integral flanges on the outer ring and the inner ring with an integral flange and a support washer. These bearings can be used as locating bearings, guiding the shaft axially in both directions.

Bearings of N design

have two integral flanges on the inner ring and a smooth outer ring. Within certain limits, an axial displacement of the shaft in relation to the housing can be accommodated in both directions.

Cylindrical roller bearings

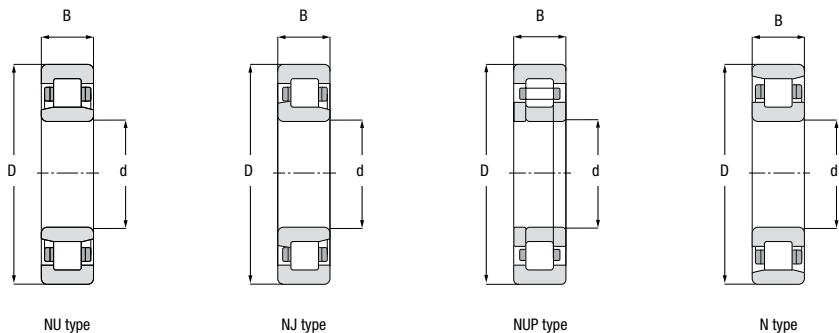

Main dimensions (mm)				Load rating (kN)		Limiting speeds * (rpm)	Weight (kg)	Designation	Thrust collar
d	D	B	B1**	Dynamic (C)	Static (C0)				
17	40	12	-	17	14	16830	0,066	N 203	
	40	12	-	17	14	16830	0,07	NJ 203	
	47	14	-	24	20	15300	0,12	N 303	
20	47	14	-	25	22	14535	0,11	N 204	
	47	14	-	25	22	14535	0,11	NJ 204	
	47	14	-	25	22	14535	0,11	NU 204	
	47	18	-	38,5	31	19200		N 2204	
	52	15	-	35	25	13700	0,15	N 304	
	52	15	6,5	35	25	13700	0,17	NJ 304	HJ 304
	52	21	-	49,5	39	16800	0,22	N 2304	
25	52	21	-	49,5	39	16800	0,22	NUP 2304	
	52	15	-	28	26	12240	0,13	N 205	
	52	15	-	28	26	12240	0,15	NJ 205	HJ 205
	52	15	-	28	26	12240	0,14	NU 205	HJ 205
	52	15	-	28	26	12240	0,14	NUP 205	-
25	52	18	-	41,5	34,5	15600	0,16	N 2205	
	52	18	6,5	33	33	12240	0,18	NJ 2205	HJ 2205
	52	18	6,5	33	33	12240	0,17	NU 2205	HJ 2205
	52	18	6,5	33	33	12240	0,17	NUP 2205	-
	62	17	-	46	36	11475	0,24	N 305	-
	62	17	7	46	36	11475	0,29	NJ 305	HJ 305
	62	17	-	46	36	11475	0,28	NUP 305	HJ 305
	62	24	-	67,5	56	13200	0,34	N 2305	-
	62	24	8	63	54	11475	0,39	NJ 2305	HJ 2305
	62	24	8	63	54	11475	0,38	NU 2305	HJ 2305
62	24	-	63	54	11475	0,38	NUP 2305	-	

Main dimensions (mm)				Load rating (kN)		Limiting speeds * (rpm)	Weight (kg)	Designation	Thrust collar
d	D	B	B1**	Dynamic (C)	Static (C0)				
30	62	16	-	43	36	10710	0,2	N 206	
	62	16	7	43	36	10710	0,24	NJ 206	HJ 206
	62	16	7	43	36	10710	0,23	NU 206	HJ 206
	62	16	-	43	36	10710	0,22	NUP 206	-
	62	20	-	58	50	13200		N 2206	-
	62	20	-	54	48	10710	0,27	NJ 2206	-
	62	20	-	54	48	10710	0,26	NU 2206	-
	62	20	-	54	48	10710	0,27	NUP 2206	-
	72	19	-	57	47	9180	0,36	N 306	-
	72	19	8,5	57	47	9180	0,41	NJ 306	HJ 306
	72	19	8,5	57	47	9180	0,4	NU 306	HJ 306
	72	19	-	57	47	9180	0,38	NUP 306	-
	72	27	-	88	77,5	11600	0,53	N 2306	-
	72	27	-	81	74	9180	0,54	NJ 2306	-
	72	27	-	81	74	9180	0,53	NU 2306	-
35	72	27	-	81	74	9180	0,55	NUP 2306	-
	72	17	-	55	47	9180	0,3	N 207	
	72	17	7	55	47	9180	0,31	NJ 207	HJ 207
	72	17	7	55	47	9180	0,3	NU 207	HJ 207
	72	17	-	55	47	9180	0,32	NUP 207	-
	72	23	-	73	65,5	12000	0,4	N 2207	-
	72	23	-	68	62	9180	0,41	NJ 2207	-
	72	23	-	68	62	9180	0,4	NU 2207	-
	72	23	-	68	62	9180	0,42	NUP 2207	-
	80	21	-	74	62	8415	0,48	N 307	-
	80	21	9,5	74	62	8415	0,55	NJ 307	HJ 307
	80	21	9,5	74	62	8415	0,46	NU 307	HJ 307
	80	21	-	74	62	8415	0,51	NUP 307	-
	80	31	-	117	109	10200	0,74	N 2307	-
	80	31	-	104	96	8415	0,73	NJ 2307	-
80	31	-	104	96	8415	0,72	NU 2307	-	
80	31	-	104	96	8415	0,75	NUP 2307	-	
40	80	18	-	61	52	8415	0,37	N 208	-
	80	18	8,5	61	52	8415	0,43	NJ 208	HJ 208
	80	18	8,5	61	52	8415	0,42	NU 208	HJ 208
	80	18	-	61	52	8415	0,4	NUP 208	-
	80	23	-	65,5	62	10000	0,48	N 2208	-
	80	23	9	80	74	8415	0,55	NJ 2208	HJ 2208
	80	23	9	80	74	8415	0,49	NU 2208	HJ 2208
	80	23	-	80	74	8415	0,56	NUP 2208	-
	90	23	-	91	76	7268	0,64	N 308	-
	90	23	11	91	76	7268	0,67	NJ 308	HJ 308
	90	23	11	91	76	7268	0,65	NU 308	HJ 308
	90	23	-	91	76	7268	0,68	NUP 308	-

Main dimensions (mm)				Load rating (kN)		Limiting speeds * (rpm)	Weight (kg)	Designation	Thrust collar
d	D	B	B1**	Dynamic (C)	Static (C0)				
40	90	33	-	91,5	88	8200	0,93	N 2308	-
	90	33	-	126	118	7268	0,96	NJ 2308	-
	90	33	-	126	118	7268	0,94	NU 2308	-
	90	33	-	126	118	7268	0,98	NUP 2308	-
45	85	19	-	68	63	7268	0,43	N 209	-
	85	19	8,5	68	63	7268	0,49	NJ 209	HJ 209
	85	19	8,5	68	63	7268	0,48	NU 209	HJ 209
	85	19	-	68	63	7268	0,45	NUP 209	-
	85	23	-	68	68	9000	0,52	N 2209	-
	85	23	-	83	80	7268	0,54	NJ 2209	-
	85	23	-	83	80	7268	0,52	NU 2209	-
	85	23	-	83	80	7268	55	NUP 2209	-
	100	25	-	110	98	6503	0,88	N 309	-
	100	25	11,5	110	98	6503	1,05	NJ 309	HJ 309
	100	25	11,5	110	98	6503	1	NU 309	HJ 309
	100	25	-	110	98	6503	0,95	NUP 309	-
	100	36	-	110	104	7400	1,24	N 2309	-
	100	36	-	157	150	6503	1,35	NJ 2309	-
	100	36	-	157	150	6503	1,3	NU 2309	-
	100	36	-	157	150	6503	1,35	NUP 2309	-
50	90	20	-	72	68	6885	0,48	N 210	-
	90	20	9	72	68	6885	0,5	NJ 210	HJ 210
	90	20	9	72	68	6885	0,49	NU 210	HJ 210
	90	20	-	72	68	6885	0,51	NUP 210	-
	90	23	-	71	73,5	8100	0,52	N 2210	-
	90	23	-	88	86	6885	0,59	NJ 2210	-
	90	23	-	88	86	6885	0,56	NU 2210	-
	90	23	-	88	86	6885	0,59	NUP 2210	-
	110	27	-	124	110	6120	1,15	N 310	-
	110	27	13	124	110	6120	1,15	NJ 310	HJ 310
	110	27	13	124	110	6120	1,15	NU 310	HJ 310
	110	27	-	124	110	6120	1,2	NUP 310	-
	110	40	-	134	131	6700	1,67	N 2310	-
	110	40	-	182	182	6120	1,75	NJ 2310	-
110	40	-	182	182	6120	1,7	NU 2310	-	
110	40	-	182	182	6120	1,8	NUP 2310	-	
55	100	21	-	112	116	6120	0,66	N 211	-
	100	21	-	95	93	6120	0,66	NJ 211	HJ 211
	100	21	9,5	95	93	6120	0,67	NU 211	HJ 211
	100	21	9,5	95	93	6120	0,67	NUP 211	-
	100	25	-	83,5	87	7400	0,76	N 2211	-
	100	25	-	95	93	6120	0,80	NJ 2211	HJ 2211
	100	25	10	112	116	6120	0,81	NU 2211	HJ 2211
	100	25	10	112	116	6120	0,79	NUP 2211	-

Main dimensions (mm)				Load rating (kN)		Limiting speeds * (rpm)	Weight (kg)	Designation	Thrust collar
d	D	B	B1**	Dynamic (C)	Static (C0)				
60	120	29	-	153	140	5355	1,45	N 311	-
	120	29	9	153	140	5355	1,5	NJ 311	HJ 311
	120	29	9	153	140	5355	1,45	NU 311	HJ 311
	120	29	-	153	140	5355	1,55	NUP 311	-
	120	43	-	164	162	6100	2,13	N 2311	-
	120	43	9	227	227	5355	2,3	NJ 2311	HJ 2311
	120	43	9	227	227	5355	2,25	NU 2311	HJ 2311
	120	43	-	227	227	5355	2,32	NUP 2311	-
	110	22	-	106	100	5785	0,81	N 212	-
	110	22	10	106	100	5783	0,83	NJ 212	HJ 212
	110	22	10	106	100	5783	0,81	NU 212	HJ 212
	110	22	-	106	100	5783	0,86	NUP 212	-
65	110	28	-	107	116	6800	1,04	N 2212	-
	110	28	10	143	150	5783	1,15	NJ 2212	HJ 2212
	110	28	10	143	150	5783	1,1	NU 2212	HJ 2212
	110	28	-	143	150	5783	1,15	NUP 2212	-
	130	31	-	170	157	5126	1,8	N 312	-
	130	31	14,5	170	157	5126	1,9	NJ 312	HJ 312
	130	31	14,5	170	157	5126	1,8	NU 312	HJ 312
	130	31	-	170	157	5126	1,95	NUP 312	-
	130	46	-	187	188	5700	2,66	N 2312	-
	130	46	16	255	260	5126	2,8	NJ 2312	HJ 2312
	130	46	16	255	260	5126	2,75	NU 2312	HJ 2312
	130	46	-	255	260	5126	2,85	NUP 2312	-
	120	23	-	120	116	5126	1,05	N 213	-
	120	23	10	120	116	5126	1,07	NJ 213	HJ 213
120	23	10	120	116	5126	1,05	NU 213	HJ 213	
120	23	-	120	116	5126	1,1	NUP 213	-	
70	120	31	-	133	149	6300	1,37	N 2213	-
	120	31	10,5	167	176	5126	1,45	NJ 2213	HJ 2213
	120	31	-	167	176	5126	1,5	NUP 2213	-
	140	33	-	208	192	4590	2,25	N 313	-
	140	33	15,5	208	192	4590	2,3	NJ 313	HJ 313
	140	33	15,5	208	192	4590	2,25	NU 313	HJ 313
	140	48	-	208	212	5200	3,2	N 2313	-
	140	48	18	279	284	4590	3,35	NJ 2313	HJ 2313
	140	48	-	279	284	4590	3,45	NUP 2313	-
	125	24	-	134	134	4820	1,15	N 214	-
	125	24	11	134	134	4820	1,15	NJ 214	HJ 214
	125	24	11	134	134	4820	1,15	NU 214	HJ 214
125	24	-	134	134	4820	1,2	NUP 214	-	
125	31	-	132	151	5900	1,44	N 2214	-	
125	31	11,5	176	189	4820	1,55	NJ 2214	HJ 2214	
125	31	-	176	189	4820	1,55	NUP 2214	-	

Main dimensions (mm)				Load rating (kN)		Limiting speeds * (rpm)	Weight (kg)	Designation	Thrust collar
d	D	B	B1**	Dynamic (C)	Static (C0)				
70	150	35	-	231	223	4284	2,75	N 314	-
	150	35	15,5	231		4284	2,8	NJ 314	HJ 314
	150	35	15,5	231		4284	2,75	NU 314	HJ 314
	150	51	-	247	262	4800	3,9	N 2314	-
	150	51	18,5	309	319	4284	4	NJ 2314	HJ 2314
75	130	25	-	147	153	4590	1,25	N 215	-
	130	25	11	147	153	4590	1,3	NJ 215	HJ 215
	130	25	11	147	153	4590	1,25	NU 215	HJ 215
	130	25	-	147	153	4590	1,3	NUP 215	-
	130	31	-	144	162	5500	1,52	N 2215	-
	130	31	-	182	204	4590	1,6	NJ 2215	-
	160	37	-	274	260	4055	3,3	N 315	-
	160	37	16,6	274	260	4055	3,3	NU 315	HJ 315
	160	55	-	286	300	4500	4,77	N 2315	-
	160	55	19,5	372	392	4055	5	NJ 2315	HJ 2315
80	140	26	-	157	163	4284	1,5	N 216	-
	140	26	12,5	157	163	4284	1,55	NJ 216	HJ 216
	140	26	12,5	157	163	4284	1,5	NU 216	HJ 216
	140	26	12,5	157	163	4284	1,6	NUP 216	-
	140	33	-	163	189	5100	1,89	N 2216	-
	140	33	12,5	208	240	4284	2,05	NJ 2216	H 2216
	170	39	-	294	284	3825	3,9	N 316	-
	170	39	17	294	284	3825	3,95	NU 316	HJ 316
	170	58	-	305	330	4200	5,67	N 2316	-
	170	58	20	407	431	3825	6	NJ 2316	HJ 2316
85	150	28	-	186	196	4055	1,9	N 217	-
	150	28	12,5	186	196	4055	1,95	NJ 217	HJ 217
	150	36	-	188	218	4800	2,39	N 2217	-
	180	41	-	333	328	3672	4,7	N 317	-
	180	41	18,5	333	328	3672	4,7	NU 317	HJ 317
	180	60	-	350	380	4000	6,75	N 2317	-
90	160	30	-	204	216	3825	2,35	N 218	-
	160	40	-	219	248	4600	3,04	N 2218	-
	190	43	-	358	353	3443	5,4	N 318	-
	190	43	18,5	358	353	3443	5,45	NU 318	HJ 318
	190	43	-	350	355	3900	-	N 2318	-

* For applications close to the limiting speeds please contact Codex QA department.

** With thrust collar.

Spherical roller bearings

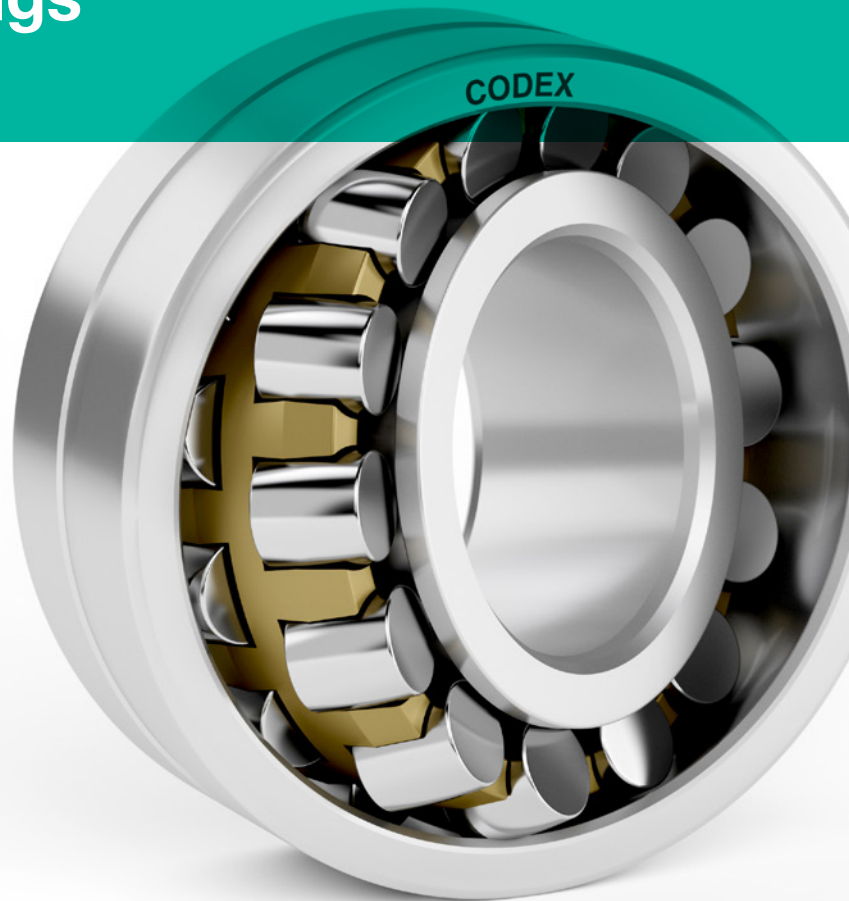

Spherical roller bearings are designed to withstand heavy radial and axial loads as well as high degrees of misalignment. Variants with a taper bore allow mounting using an adapter sleeve.

Spherical roller bearings are particularly suitable for heavy mechanical applications with heavy axial loads and where it is difficult to align the seats. These bearings are suitable for applications with severe operating conditions involving impact or vibration (heavy machinery, vibrating screens, crushers, etc.).

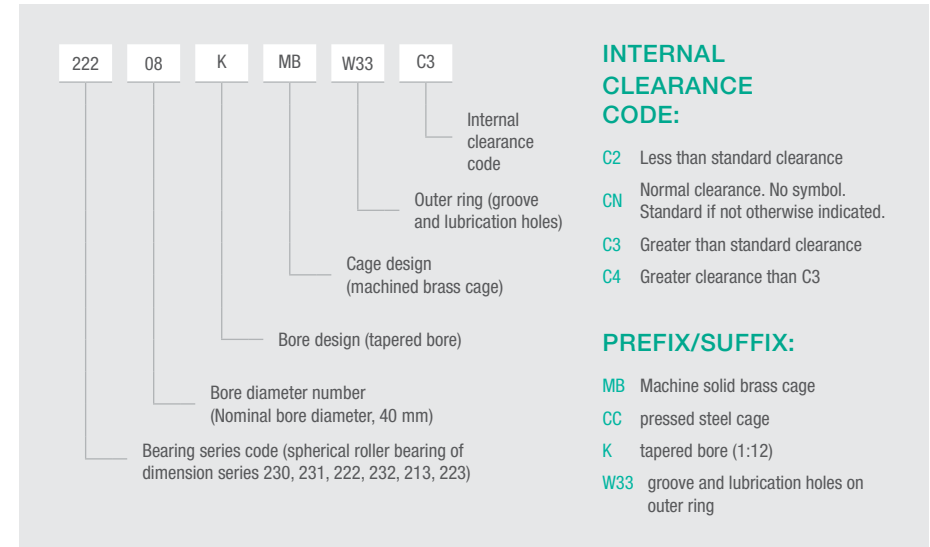

CODEX BASIC TYPES & SERIES

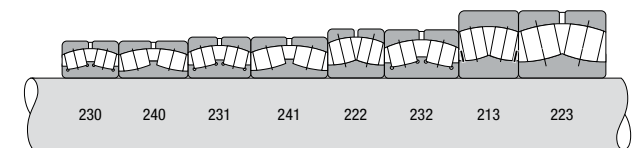

Main dimensions (mm)			Load ratings (kN)		Limiting speeds * (rpm)	Weight (kg)	Designation	
d	D	B	Dynamic (Cr)	Cor static (Cor)			Cylindrical bore	Taper bore
160	240	60	570	855	1300	10	23032	23032K
	270	86	961	1345	1000	19,7	23132	23132K
	290	80	977	1250	1700	22,2	22232	22232K
	290	104	1170	1610	1100	30	23232	23232K
	340	114	1560	1910	1100	51	22332	22332K
170	260	67	700	1050	1200	13	23034	23034K
	280	88	1005	1460	1000	21,1	23134	23134K
	310	86	1100	1420	1500	28	22234	22234K
	310	110	1360	1880	900	35,7	23234	23234K
	360	120	1730	2108	1100	60	22334	22334K
180	280	74	810	1215	1200	17,6	23036	23036K
	300	96	1150	1705	900	27,1	23136	23136K
	320	86	1160	1525	1400	29,4	22236	22236K
	320	112	1460	2070	900	37,9	23236	23236K
	380	126	1945	2396	1000	70	22336	22336K
190	290	75	860	1335	1100	20	23038	23038K
	320	104	1230	2060	850	35,3	23138	23138K
	340	92	1250	1670	1300	35,3	22238	22238K
	340	120	1600	2332	800	46,1	23238	23238K
	400	132	2070	2560	900	81	22338	22338K
200	310	82	975	1450	900	24	23040	23040K
	340	112	1556	2420	800	47,6	23140	23140K
	360	98	1434	1185	1100	47,7	22240	22240K
	360	128	1805	2640	750	55,4	23240	23240K
	420	138	2250	2832	750	94	22340	22340K
220	340	90	1160	1800	850	28,8	23044	23044K
	370	120	1760	2690	700	51,5	23144	23144K
	400	108	1710	2313	1000	61,5	22244	22244K
	400	144	2995	3365	670	78,5	23244	23244K
	460	145	2613	3362	660	120	22344	22344K
240	360	92	1266	2040	800	32,4	23048	23048K
	400	128	2020	3120	670	63,7	23148	23148K
	440	120	2134	2920	730	82	22248	22248K
	440	160	2830	4206	630	107,3	23248	23248K
260	400	104	1555	2482	750	47,7	23052	23052K
	440	144	2490	3817	600	88,2	23152	23152K
280	420	106	1690	2788	700	50,9	23056	23056K
	460	146	2639	4148	600	103	23156	23156K
300	460	118	2068	3378	650	71,4	23060	23060K

* For applications close to the limiting speeds please contact Codex QA department.



Axial thrust bearings

Thrust ball bearings

Thrust ball bearings come in single-direction (able to withstand axial load in a single direction) and double-direction type (able to withstand load from both directions). They can sustain axial loads but no radial loads. They are classified into those with flat seat or aligning seat depending on the shape of the outer ring seat (housing washer).

Standard cage material is steel sheet.

NOMENCLATURE:

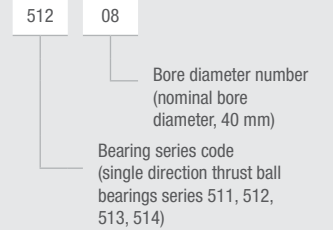

CODEX BASIC TYPES & SERIES

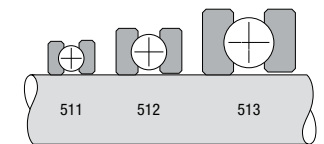

Axial thrust bearings

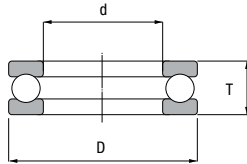

Main dimensions (mm)			Load ratings (kN)		Limiting speeds* (rpm)	Weight (kg)	Designation
d	D	T	Dynamic (Cr)	Static (Cor)			
10	24	9	10	14	7000	0,019	51100
	26	11	12,6	17,1	6000	0,028	51200
12	26	9	10,3	15,4	7000	0,021	51101
	28	11	13	19	6000	0,031	51201
15	28	9	10,5	16,8	6000	0,023	51102
	32	12	15,6	24,4	5000	0,043	51202
17	30	9	11,4	19,6	6300	0,025	51103
	35	12	17,2	27,5	5000	0,053	51203
20	35	10	12,7	20,8	5600	0,038	51104
	40	14	22,5	37,5	4500	0,083	51204
25	42	11	19,7	37	4800	0,056	51105
	47	15	28	50,5	3800	0,111	51205
	52	18	36	61,5	3200	0,169	51305
30	47	11	20,6	42	4300	0,064	51106
	52	16	29,5	58	3400	0,137	51206
	60	21	43	78,5	2800	0,267	51306
35	52	12	22,1	49,5	4000	0,081	51107
	62	18	39,5	78	3000	0,21	51207
	68	24	56	105	2400	0,386	51307
40	60	13	30,1	62,9	4200	0,12	51108
	68	19	48,4	92,4	3200	0,27	51208
	78	26	73,5	135	2700	0,536	51308
45	65	14	31,3	69,2	4000	0,143	51109
	73	20	47	105	3000	0,31	51209
	85	28	87,2	164	2400	0,672	51309
50	70	14	32,3	75,5	3800	0,153	51110
	78	22	51,9	111	2800	0,378	51210
	95	31	96,6	202	2200	0,931	51310
55	78	16	36,5	93,2	3300	0,227	51111
	90	25	73,6	159	2500	0,599	51211
	105	35	123	246	1900	1,31	51311
60	85	17	46,4	113	3200	0,281	51112
	95	26	71,5	169	2000	0,673	51212
	110	35	125	270	1900	1,4	51312

Main dimensions (mm)			Load ratings (kN)		Limiting speeds* (rpm)	Weight (kg)	Designation
d	D	T	Dynamic (Cr)	Static (Cor)			
65	90	18	44,6	117	2300	0,324	51113
	100	27	76,4	189	2400	0,756	51213
	115	36	129	287	1800	1,54	51313
70	95	18	46,6	127	2800	0,346	51114
	105	27	76,9	199	2200	0,793	51214
	125	40	158	340	1700	2	51314
75	100	19	49,8	136	2700	0,389	51115
	110	27	81,2	209	2200	0,845	51215
	135	44	193	426	1600	2,6	51315
80	105	19	50	141	2700	0,417	51116
	115	28	86,4	219	2000	0,931	51216
	140	44	164	395	1300	2,74	51316
85	110	19	51,5	150	2700	0,44	51117
	125	31	105	264	2000	1,22	51217
	150	49	227	517	1300	3,57	51317
90	120	22	66,9	190	1900	0,646	51118
	135	35	114	310	1400	1,69	51218
	155	50	237	556	1100	3,83	51318
100	135	25	95,3	268	2000	0,96	51120
	150	38	135	375	1300	2,25	51220
	170	55	266	628	1060	4,98	51320
110	145	25	97,8	288	1900	1,04	51122
	160	38	136	395	900	2,42	51222
	190	63	280	744	890	7,19	51322
120	155	25	90	310	1600	1,12	51124
	170	39	141	430	1200	2,7	51224
	210	70	369	977	800	9,7	51324

* For applications close to the limiting speeds please contact Codex QA department.

Spherical plain bearings and rod ends



Spherical plain bearings utilise inner and outer ring with spherical sliding surface and can accommodate heavy radial loads as well as bi-directional axial loads at the same time.

The inner ring has a spherical, convex, outside diameter and the outer ring has a correspondingly spherical, concave, inside surface. Spherical plain bearings are designed to carry radial and axial loads and are ideal for static and oscillatory applications where moderate misalignment may exist. These kinds of bearings are suitable for heavy-duty vehicles, agricultural equipment, construction, mining and logging equipment.

NOMENCLATURE:

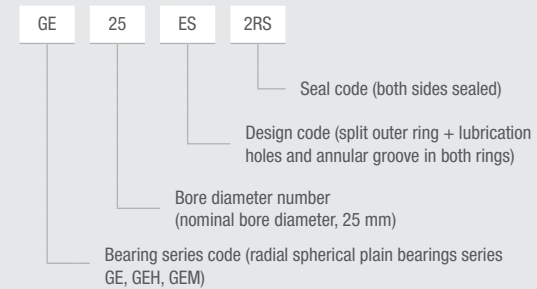

SHIELD CODE:

No symbol: Open type
 2RS: double side rubber seal

PREFIX/SUFFIX:

E: split outer ring
 S: lubrication holes and annular groove in both rings
 ES: E+S
 C: maintenance free

CODEX BASIC TYPES & SERIES

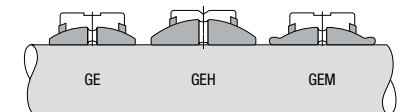

Steel/steel spherical plain bearings

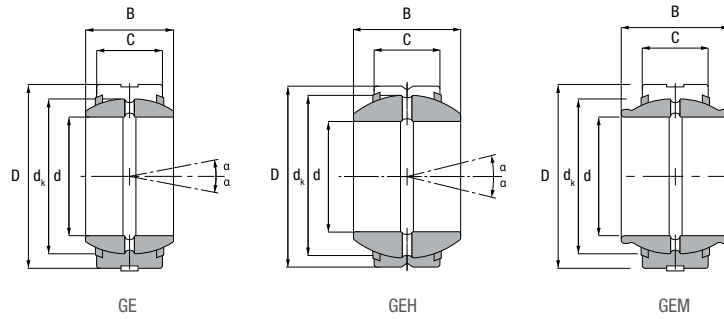

Main dimensions (mm)						Load ratings (kN)		Weight (kg)	Designation
d	D	B	C	dk	α	Dynamic (Cr)	Static (Cor)		
6	14	6	4	10	13	3,4	17	0,004	GE6
8	16	8	5	13	15	5,5	27	0,007	GE8
	19	11	6	16	21	8,1	40	0,014	GEH8
10	19	9	6	16	12	8,1	40	0,011	GE10
	22	12	7	18	18	10	53	0,021	GEH10
12	22	10	7	18	10	10	53	0,017	GE12
	26	15	9	22	18	16	84	0,036	GEH12
15	26	12	9	22	8	16	84	0,026	GE15
	30	16	10	25	16	21	106	0,048	GEH15
17	30	14	10	25	10	21	106	0,04	GE17
	35	20	12	29	19	30	146	0,08	GEH17
20	35	16	12	29	9	30	146	0,064	GE20
	42	25	16	35,5	17	48	240	0,152	GEH20
25	42	20	16	35,5	7	48	240	0,115	GE25
	47	28	18	40,7	17	62	310	0,199	GEH25
	42	29	16	35,5	4	48	240	0,13	GEM25
30	47	22	18	40,7	6	62	310	0,149	GE30
	55	32	20	47	17	79	399	0,296	GEH30
35	47	30	18	40,7	4	62	310	0,16	GEM30
	55	25	20	47	6	79	399	0,228	GE35
40	62	35	22	53	16	99	495	0,402	GEH35
	55	35	20	47	4	79	399	0,25	GEM35
45	62	28	22	53	7	99	495	0,318	GE40
	68	40	25	60	17	127	637	0,535	GEH40
50	62	38	22	53	4	99	495	0,34	GEM40
	68	32	25	60	7	127	637	0,421	GE45
55	75	43	28	66	15	156	780	0,698	GEH45
	68	40	25	60	4	127	637	0,45	GEM45
60	75	35	28	66	6	156	780	0,562	GE50
	90	56	36	80	17	245	1220	1,42	GEH50
90	75	43	28	66	4	156	780	0,59	GEM50

Main dimensions (mm)						Load ratings (kN)		Weight (kg)	Designation
d	D	B	C	dk	α	Dynamic (Cr)	Static (Cor)		
60	90	44	36	80	6	245	1220	1,03	GE60
	105	63	40	92	17	313	1560	2,09	GEH60
70	90	54	36	80	3	245	1220	1,06	GEM60
	105	49	40	92	6	313	1560	1,57	GE70
80	120	70	45	105	16	400	2000	3,01	GEH70
	120	55	45	105	6	400	2000	2,32	GE80
90	130	75	50	115	14	488	2440	3,61	GEH80
	130	60	50	115	5	488	2440	2,79	GE90

* For applications close to the limiting speeds please contact Codex QA department.

ROD ENDS

Spherical plain bearing rod ends are bearings that consist of a spherical plain bearing in the eye-shaped head of the rod end housing. Available with an internal (female) thread, external (male) thread, left-handed or right-handed thread.

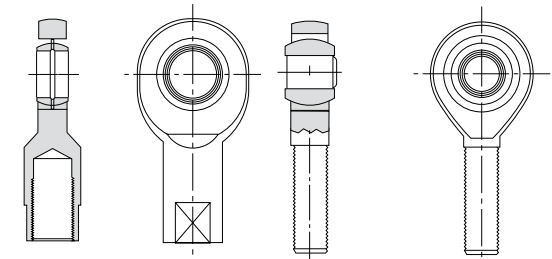

NOMENCLATURE:

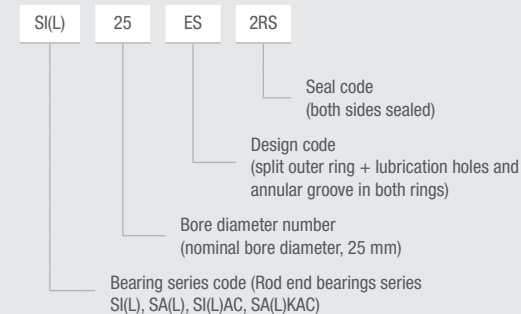

SHIELD CODE:

No symbol – Open type
2RS - double side rubber seal

PREFIX/SUFFIX:

- L left-hand thread
- E split on bearing outer ring
- S (suffix) lubrication holes and annular groove in both rings
- ES E+S
- C maintenance-free rod ends
- M sliding surface steel/bronze
- S (prefix) stainless steel rod end

Rod ends with a female thread SI/SIL and a male thread SA/SAL

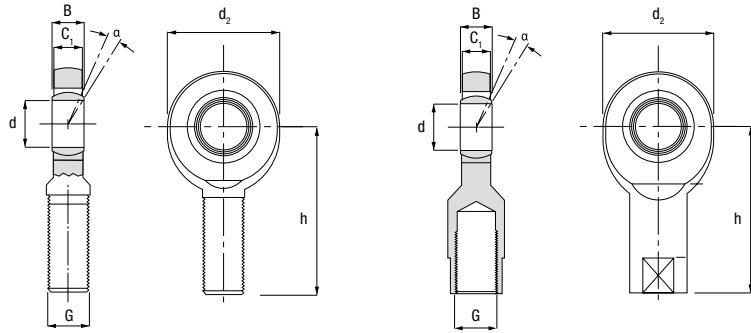

Main dimensions (mm)							Load ratings (kN)		Weight (kg)	Designations	
d	d2	G	B	C1 (max)	h	α	C	C0		Right-hand thread	Left-hand thread
6	21	M6	6	4,5	30	13	3,4	8,1	0,023	SI6	SIL6
	21	M6	6	4,5	36	13	3,4	5,5	0,016	SA6	SAL6
8	24	M8	8	6,5	36	15	5,5	12,9	0,04	SI8	SIL8
	24	M8	8	6,5	42	15	5,5	10	0,026	SA8	SAL8
10	29	M10	9	7,5	43	12	8,1	17,6	0,065	SI10	SIL10
	29	M10	9	7,5	48	12	8,1	16	0,05	SA10	SAL10
12	34	M12	10	8,5	50	10	10	24,5	0,108	SI12	SIL12
	34	M12	10	8,5	54	10	10	23	0,068	SA12	SAL12
15	40	M14	12	10,5	61	8	16	36	0,169	SI15	SIL15
	40	M14	12	10,5	63	8	16	32	0,12	SA15	SAL15
17	46	M16	14	11,5	67	10	21	45	0,235	SI17	SIL17
	46	M16	14	11,5	69	10	21	44	0,19	SA17	SAL17
20	53	M20X1,5	16	13,5	77	9	30	60	0,335	SI20	SIL20
	53	M20X1,5	16	13,5	78	9	30	60	0,3	SA20	SAL20
25	64	M24X2	20	18	94	7	48	83	0,665	SI25	SIL25
	64	M24X2	20	18	94	7	48	83	0,555	SA25	SAL25

SIKAC/SILKAC Rod ends with a threaded shank

Steel-on-bronze rod ends with a female thread SIKAC/SI(L)KAC

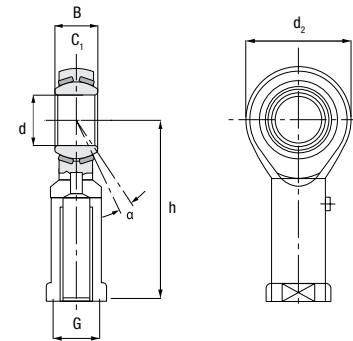

Main dimensions (mm)							Load ratings (kN)		Weight (kg)	Designations	
d	d2	G	B	C1 (max)	h	α	C	C0	Kg	Right-hand thread	Left-hand thread
6	18	M6	9	6,75	30	13	4,3	5,3	0,026	SIKAC 6 M	SILKAC 6 M
8	22	M8	12	9	36	14	6,8	8,5	0,044	SIKAC 8 M	SILKAC 8 M
10	26	M10	14	10,5	43	14	10	11	0,072	SIKAC 10 M	SILKAC 10 M
12	30	M12	16	12	50	13	13	14	0,108	SIKAC 12 M	SILKAC 12 M
14	34	M14	19	13,5	57	16	17	20	0,161	SIKAC 14 M	SILKAC 14 M
16	38	M16	21	15	64	15	21	25	0,225	SIKAC 16 M	SILKAC 16 M
18	42	M18X1,5	23	16,5	71	15	26	30	0,295	SIKAC 18 M	SILKAC 18 M
20	46	M20X1,5	25	18	77	15	31	35	0,382	SIKAC 20 M	SILKAC 20 M
22	50	M22X1,5	28	20	84	15	38	43	0,488	SIKAC 22 M	SILKAC 22 M
25	60	M24X2	31	22	94	15	47	65	0,749	SIKAC 25 M	SILKAC 25 M

Steel-on-bronze rod ends with a male thread
SAKAC/SA(L)KAC

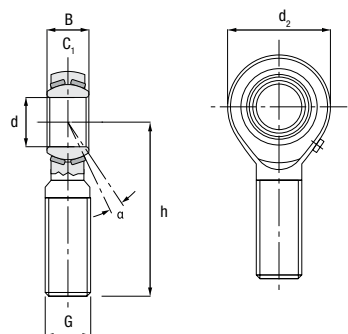

Main dimensions (mm)							Load ratings (kN)		Weight (kg)	Designations	
d	d2	G	B	C1 (max)	h	α	C	C0	Kg	Right-hand thread	Left-hand thread
6	18	M6	9	6,75	36	13	4,3	5,3	0,026	SAKAC 6 M	SALKAC 6 M
8	22	M8	12	9	42	14	6,8	8,5	0,044	SAKAC 8 M	SALKAC 8 M
10	26	M10	14	10,5	48	14	10	11	0,072	SAKAC 10 M	SALKAC 10 M
12	30	M12	16	12	54	13	13	14	0,108	SAKAC 12 M	SALKAC 12 M
14	34	M14	19	13,5	60	16	17	20	0,161	SAKAC 14 M	SALKAC 14 M
16	38	M16	21	15	66	15	21	25	0,225	SAKAC 16 M	SALKAC 16 M
18	42	M18X1,5	23	16,5	72	15	26	30	0,295	SAKAC 18 M	SALKAC 18 M
20	46	M20X1,5	25	18	78	15	31	35	0,382	SAKAC 20 M	SALKAC 20 M
22	50	M22X1,5	28	20	84	15	38	43	0,488	SAKAC 22 M	SALKAC 22 M
25	60	M24X2	31	22	94	15	47	65	0,749	SAKAC 25 M	SALKAC 25 M

Solutions for agriculture



INTEGRATED FLANGE, MAINTENANCE FREE BEARING for modern agriculture

In order to satisfy modern trends in agricultural equipment demand such as longer and faster operation with minimised work stops, Codex has developed its own range of AGRI HUB bearings, designed as a durable solution for agricultural machinery that do not require maintenance or service and can be simply replaced at the end of their lifetime.

Codex 0004 (with 4 attachment holes in the outer ring) and Codex 0012 (with 5 attachment holes in the outer ring) are the perfect solutions for disc harrows and tillers that operate in demanding & highly contaminated environments.

They are designed with integrated flange and cassette sealing to protect the bearing from dirt and contaminants. They are greased and sealed for the life of the bearing.

CHARACTERISTICS

Tractor speed: up to 20 km/h
Bolt mounting torque: 100 Nm

Nut torque: 290 Nm
Zinc-coated flange surface

- Corrosion-resistant
- Disc diameter up to 610
- Maintenance-free

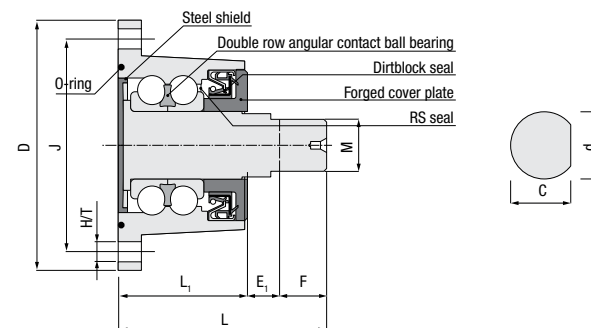

Designation	J	D	H/T	d	C	M	L	L1	E	F	Co (kN)	Cr (kN)	Weight (kg)
CODEX 0004	98	117	4xM12x1,25	27,95	25,4	M22x1,5	102	60	17	25	60,19	46,41	2,51
CODEX 0012	98	117	5xM12x1,25	27,95	25,4	M22x1,5	102	60	17	25	60,19	46,41	2,51

INSERT BEARINGS

206 KRRB

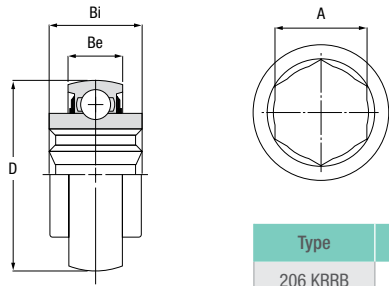

Type	Bi	A	D	Be	Weight
206 KRRB	24mm	25,43mm	62mm	16mm	0.26kg

W209PPB25 and W209PPB30

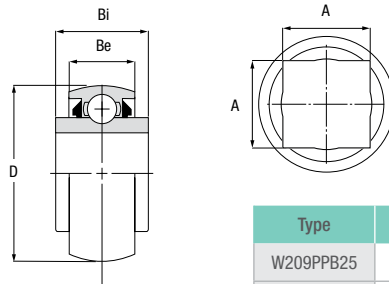

Type	Bi	A	D	Be	Weight
W209PPB25	45mm	25,6mm	90mm	29mm	0.79kg
W209PPB30	45mm	30,55mm	90mm	29mm	0.93kg

UC 511

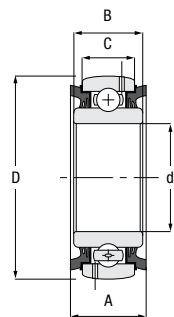

Type	A	d	D	C	B	Weight
UC 511	45mm	55mm	100mm	34mm	40mm	1kg

AGRICULTURAL BEARINGS

ST491

Type 1

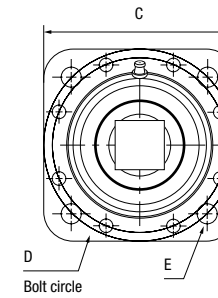
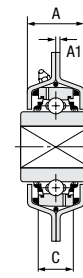

Type 2

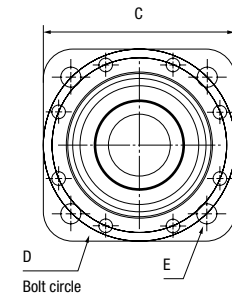

Type	Hole size	A	E	A1	C	D	Weight	Type
ST 491	44.4mm	42,86mm	13mm	3mm	127mm	127mm	1.5kg	2
ST 491	30.5mm	42,86mm	13mm	3mm	127mm	127mm	1.6kg	1

ST740

Type 1

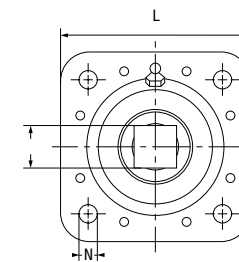
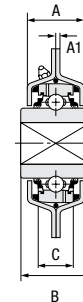

Type 2

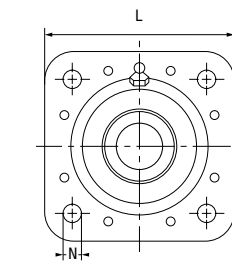

Type	Hole size	B	A	N	A1	L	Weight	Type
ST 740-36	36mm	55.5mm	45mm	13.5mm	3.5mm	139,7	2.60kg	1
ST 740-39	39,25mm	55.5mm	45mm	13.5mm	3.5mm	139,7	2.43kg	1
ST 740-55	55,575mm	55.5mm	45mm	13.5mm	3.5mm	139,7	2.18kg	2

KSS-20

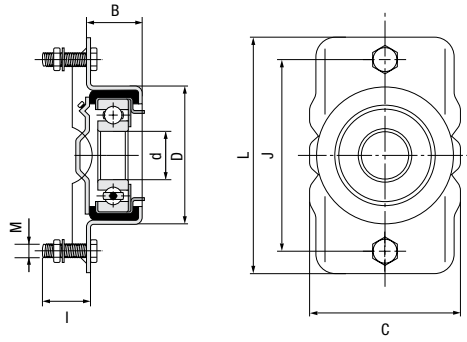

Type	B	Hole size	D	I	M	C	L	J	Weight
KSS-20 kit	36mm	20mm	65mm	26mm	8mm	65mm	103mm	85mm	0.53kg

Codex Bearing Units



Ball bearing units are used in many industrial applications due to their cost-efficiency. Ball bearing units are composed of an insert bearing mounted in a cast housing in various designs.

An insert bearing is a deep groove ball bearing with a convex outside surface on outer ring and an extended inner ring with two bolts for mounting it on a shaft

Housings designs are available as flanged and take-up units and are made from durable HT200 cast iron material.

Housings are equipped with a grease nipple for external lubrication. Since the insert bearings itself requires high precision, the used grease should be of a particularly fine quality.

UC	205
Insert bearing	basic bearing series

NOMENCLATURE:

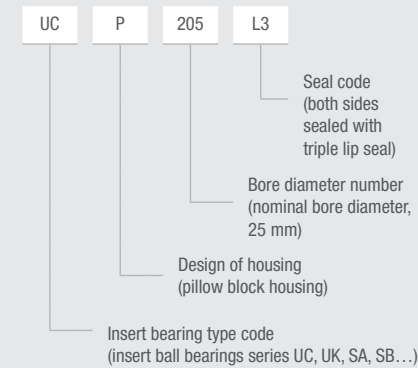

DESIGN OF HOUSING:

- P (pillow block)
- F (4-bolt flange unit)
- FL (2-bolt flange unit)

SEALING OF INSERT BEARINGS:

- DUAL SEAL**
Nitrile rubber single lip seal with an additional shield
- TRIPLE LIP SEAL**
Seal for contaminated environments
- FIVE LIP SEAL**
Seal for very contaminated environments

Housings and insert bearing combinations:

UCP Pillow Blocks

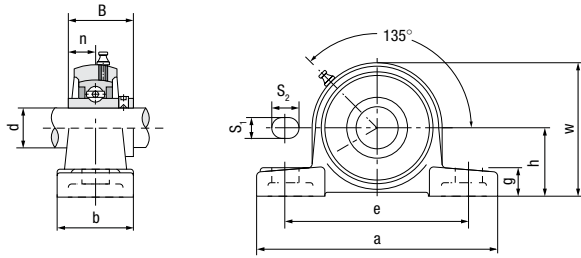

Bearing Unit	Bearing housing	Insert bearing	Main dimensions (mm)										Bolt	Weight (kg)	
			d	h	a	e	b	S1	S2	g	w	B			n
UCP201	P201	UC201	12	30,2	127	95	38	13	19	14	62	31	12,7	M10	0,65
UCP202	P202	UC202	15	30,2	127	95	38	13	19	14	62	31	12,7	M10	0,64
UCP203	P203	UC203	17	30,2	127	95	38	13	19	14	62	31	12,7	M10	0,63
UCP204	P204	UC204	20	33,3	127	95	38	13	19	14	65	31	12,7	M10	0,64
UCP205	P205	UC205	25	36,5	140	105	38	13	19	15	71	34,1	14,3	M10	0,76
UCP206	P206	UC206	30	42,9	160	121	44	17	20	17	84	38,1	15,9	M14	1,2
UCP207	P207	UC207	35	47,6	167	127	48	17	20	18	93	42,9	17,5	M14	1,46
UCP208	P208	UC208	40	49,2	184	137	54	17	20	18	100	49,2	19	M14	1,86
UCP209	P209	UC209	45	54,0	190	146	54	17	20	20	106	49,2	19	M14	2,06
UCP210	P210	UC210	50	57,2	206	159	60	20	23	21	113	51,6	19	M16	2,61
UCP211	P211	UC211	55	63,5	219	171	60	20	23	23	125	55,6	22,2	M16	3,23
UCP212	P212	UC212	60	69,8	241	184	70	20	23	25	138	65,1	25,4	M16	4,40

UCF 4-Bolt Flange Units

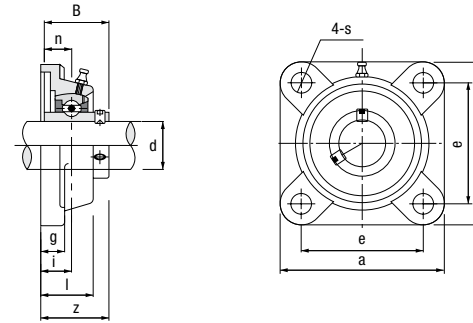

Bearing Unit	Bearing housing	Insert bearing	Main dimensions (mm)										Bolt	Weight (kg)
			d	a	e	i	g	l	s	z	B	n		
UCF201	F201	UC201	12	86	64	15	12	25,5	12	33,3	31	12,7	M10	0,59
UCF202	F202	UC202	15	86	64	15	12	25,5	12	33,3	31	12,7	M10	0,58
UCF203	F203	UC203	17	86	64	15	12	25,5	12	33,3	31	12,7	M10	0,57
UCF204	F204	UC204	20	86	64	15	12	25,5	12	33,3	31	12,7	M10	0,55
UCF205	F205	UC205	25	95	70	16	14	27	12	35,8	34,1	14,3	M10	0,73
UCF206	F206	UC206	30	108	83	18	14	31	12	40,2	38,1	15,9	M10	1,02
UCF207	F207	UC207	35	117	92	19	16	34	14	44,4	42,9	17,5	M12	1,33
UCF208	F208	UC208	40	130	102	21	16	36	16	51,2	49,2	19	M14	1,67
UCF209	F209	UC209	45	137	105	22	18	38	16	52,2	49,2	19	M14	2,0
UCF210	F210	UC210	50	143	111	22	18	40	16	54,6	51,6	19	M14	2,32
UCF211	F211	UC211	55	162	130	25	20	43	19	58,4	55,6	22,2	M16	3,12
UCF212	F212	UC212	60	175	143	29	20	48	19	68,7	65,1	25,4	M16	3,95

UCFL 2-Bolt Flange Units

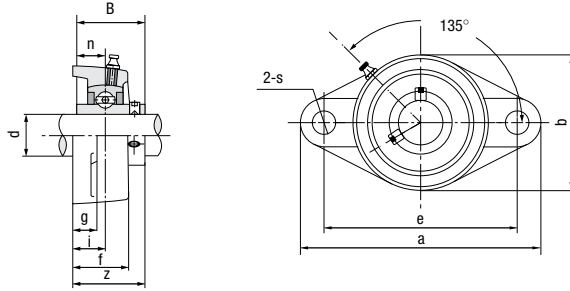

Bearing Unit	Bearing housing	Insert bearing	Main dimensions (mm)										Bolt	Weight (kg)	
			d	a	e	i	g	f	s	b	z	B			n
UCFL201	FL201	UC201	12	113	90	15	11	25,5	12	60	33,3	31	12,7	M10	0,45
UCFL202	FL202	UC202	15	113	90	15	11	25,5	12	60	33,3	31	12,7	M10	0,45
UCFL203	FL203	UC203	17	113	90	15	11	25,5	12	60	33,3	31	12,7	M10	0,45
UCFL204	FL204	UC204	20	113	90	15	11	25,5	12	60	33,3	31	12,7	M10	0,45
UCFL205	FL205	UC205	25	130	99	16	13	27	16	68	35,8	34,1	14,3	M14	0,58
UCFL206	FL206	UC206	30	148	117	18	13	31	16	80	40,2	38,1	15,9	M14	0,83
UCFL207	FL207	UC207	35	161	130	19	14	34	16	90	44,4	42,9	17,5	M14	1,1
UCFL208	FL208	UC208	40	175	144	21	14	36	16	100	51,2	49,2	19,0	M14	1,42
UCFL209	FL209	UC209	45	188	148	22	15	38	19	108	52,2	49,2	19,0	M16	1,75
UCFL210	FL210	UC210	50	197	157	22	15	40	19	115	54,6	51,6	19,0	M16	2,02
UCFL211	FL211	UC211	55	224	184	25	18	43	19	130	58,4	55,6	22,2	M16	2,8
UCFL212	FL212	UC212	60	250	202	29	18	48	23	140	68,7	65,1	25,4	M20	3,65

UC Insert bearings

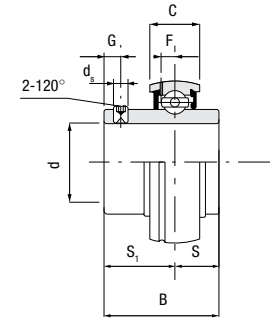

Insert bearing	Main dimensions (mm)									Dynamic load (kN)	Static load (kN)	Weight (kg)
	d	D	B	C	S	S1	G	ds	F			
UC201	12	47	31	17	12,7	18,3	4,8	M6x1	3,7	12,8	6,6	0,20
UC202	15	47	31	17	12,7	18,3	4,8	M6x1	3,7	12,8	6,6	0,19
UC203	17	47	31	17	12,7	18,3	4,8	M6x1	3,7	12,8	6,6	0,18
UC204	20	47	31	17	12,7	18,3	4,8	M6x1	3,7	12,8	6,6	0,16
UC205	25	52	34,1	17	14,3	19,8	5	M6x1	3,9	14,0	7,85	0,19
UC206	30	62	38,1	19	15,9	22,2	5	M8x1	5	19,45	11,25	0,30
UC207	35	72	42,9	20	17,5	25,4	7	M8x1	5,7	25,7	15,2	0,45
UC208	40	80	49,2	21	19	30,2	8	M8x1	6,2	29,5	18,1	0,60
UC209	45	85	49,2	22	19	30,2	8	M8x1	6,4	32,7	20,9	0,65
UC210	50	90	51,6	24	19	32,6	10	M10x1	6,5	35	23,2	0,75
UC211	55	100	55,6	25	22,2	33,4	10	M10x1	7	43,3	29,2	0,99
UC212	60	110	65,1	27	25,4	39,7	10	M10x1	7,6	47,7	32,8	1,32

SA Insert bearings

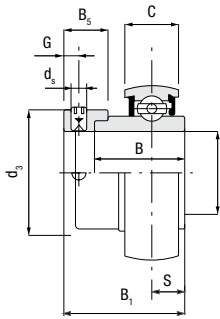

Insert bearing	Main dimensions (mm)											Dynamic load (kN)	Static load (kN)	Weight (kg)
	d	D	B	B1	C	S	ds	G	F	B5	D3			
SA201	12	40	28,6	19,1	12	6,5	M6x1	4,8	3,4	13,5	28,6	9,6	4,6	0,12
SA202	15	40	28,6	19,1	12	6,5	M6x1	4,8	3,4	13,5	28,6	9,6	4,6	0,1
SA203	17	40	28,6	19,1	12	6,5	M6x1	4,8	3,4	13,5	28,6	12,8	6,6	0,1
SA204	20	47	31	21,5	14	7,5	M6x1	4,8	4,2	13,5	33,3	12,8	6,6	0,16
SA205	25	52	31	21,5	15	7,5	M6x1	4,8	4,3	13,5	38,1	14,0	7,85	0,2
SA206	30	62	35,7	23,8	16	9,0	M8x1	6	5	15,9	44,5	19,45	11,25	0,3
SA207	35	72	38,9	25,4	17	9,5	M8x1	6,8	5,6	17,5	55,6	25,7	15,2	0,42
SA208	40	80	43,7	30,2	18	11	M8x1	6,8	5,9	18,3	60,3	29,5	18,1	0,6
SA209	45	85	43,7	30,2	19	11	M10x1	6,8	6,1	18,3	63,5	32,7	20,9	0,64
SA210	50	90	43,7	30,2	20	11	M10x1	6,8	6,5	18,3	69,9	35	23,2	0,72
SA211	55	100	48,3	32,5	21	12	M10x1	8	7	20,7	76,2	43,3	29,2	1
SA212	60	110	53,1	37,2	22	13,5	M10x1	8	7,4	22,3	84,2	47,7	32,8	1,34

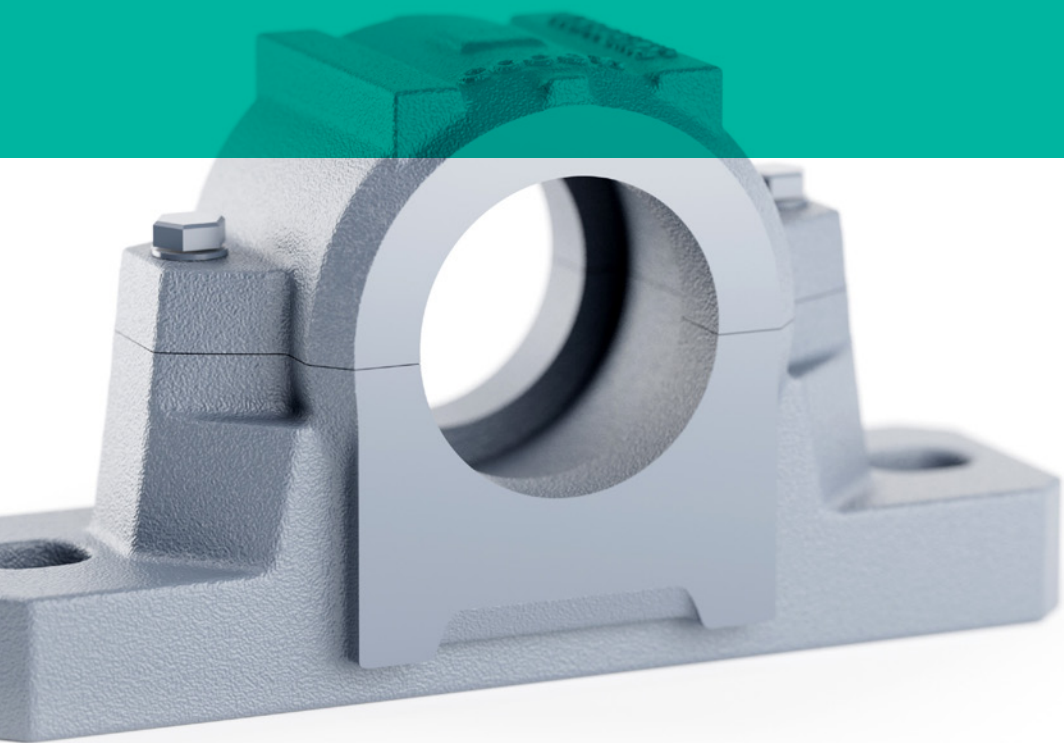

Codex SNL Plummer housings

Pillow (plummer) block housings SNL type are the most popular type on the market. They are well adapted to various applications and are designed for the best price/performance ratio.

For installed bearings, they assure the best conditions to maximize their performance, their life time and to minimize maintenance. The split plummer block housings are typically used with self-aligning ball bearings or spherical roller bearings fitted on straight or stepped shafts. The bearings can be mounted on adapter or withdrawal sleeves or directly on to cylindrical shaft seats.

Plummer block housings are split units (cap and base) and assembly is carried out by attaching both parts together with bolts. Two fixing holes on the base are available for installation of the unit to a supporting structure.

The plummer block housings are made of high-quality grey cast iron to provide high tensile strength.

Sealing arrangement

Proper sealing keeps the interior contact surfaces debris-free and the interior properly lubricated. SNL plummer (pillow) block housings are available with different standard sealing solutions.

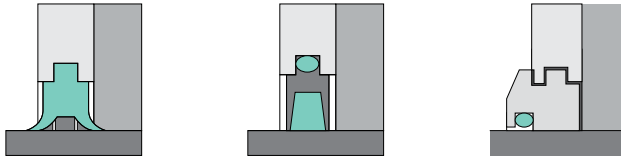

Structural properties	TSNG Double lip seal	TSN Felt strip seal	TSU Labyrinth seal
Operating temperature (°C)	-40...+100	-40...+100	-40...+200
Circumferential speed (m/s)	< 8	< 15	> 15
Possible misalignment (Degrees)	0,5...1	< 0,5	< 0,3
Relubrication			
Low friction			
Suitable for floating bearings			
Vertical installation			

DOUBLE-LIP SEALS (TSNG)

Double-lip seals are the most common seal design used with SNL split plummer blocks. These are general all-purpose elastomer seals that can protect in moderately contaminated environments. The seal is split into two 180-degree halves for easy installation. The seal element runs against the shaft surface and should be used in grease lubricated blocks.

LABYRINTH SEALS (TSU)

Labyrinth seals are made up of a single metal ring component that interconnects with the grooves in the housing to form a labyrinth gap. The inside diameter of the metal ring contains an O-ring that creates an interference fit with the shaft so that the ring will rotate with the shaft. Labyrinth seals can be used on high-speed applications and in moderately contaminated environments.

FELT SEALS OR STRIPS (TSN)

Felt seals are compatible with rubber seals but must be used for grease lubrication only. Felt seals are not suitable for dusty or moist environments. Their allowable peripheral speed, as a guideline, is 4m/s. A felt seal can be cut into two pieces that are respectively fitted into the seal grooves on the upper and lower plummer block housings. This feature greatly simplifies the assembly procedure for plummer blocks.

END COVERS (ASNH)

In some applications, the shaft end is designed to terminate inside the pillow block. For this design, positive fitting end-cover inserts are available to help seal out contaminants and retain lubricants – providing additional protection to the bearing.

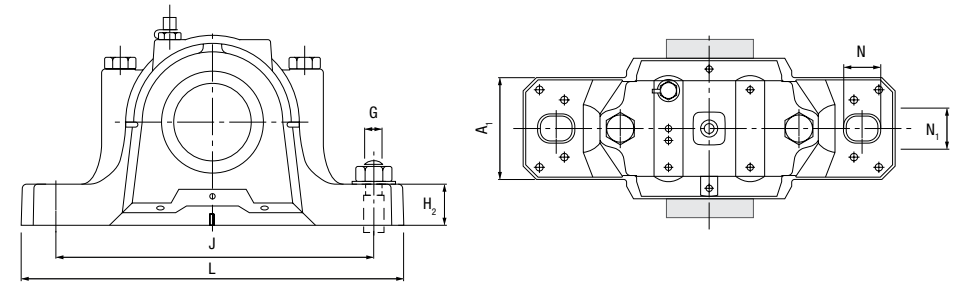

Type	A (mm)	H (mm)	H1 (mm)	L (mm)	N (mm)	N1 (mm)	J (mm)	A1 (mm)
SNL 511	95	128	70	255	23	18	210	70
SNL 512	105	134	70	255	23	18	210	70
SNL 513	110	149	80	275	24	18	230	80
SNL 515	115	155	80	280	24	18	230	80
SNL 516	120	177	95	315	28	22	260	90
SNL 517	125	183	95	320	28	22	260	90
SNL 518	140	194	100	345	28	22	290	100
SNL 520	160	218	122	380	32	26	320	110
SNL 522	175	242	125	410	32	26	350	120
SNL 524	185	271	140	410	32	26	350	120
SNL 526	190	290	150	445	35	28	380	130
SNL 528	205	302	150	500	42	35	420	150

Table of typical usage of SNL plummer block with bearing, adapter sleeve, sealing arrangement, end cover and locating ring.

Shaft Dia, (mm)	Housing No,	Bearing No,		Adapter Sleeve	Sealing Arrangement		End Cover	Locating Ring	
		Self-Alig, Ball	Spherical Roller		TSU	TSNA-G		Number	Qty
40	SNL 511	1309K	21309K	H309	-	TSNG 609	ASNH 511	100 x 9,5	2
	SNL 511	2309K	22309K	H2309	-	TSNG 609	ASNH 511	100 x 8	1
45	SNL 512	1310K	21310K	H310	-	TSNG 610	ASNH 512	110 x 10,5	2
	SNL 512	2310K	22310K	H2310	-	TSNG 610	ASNH 512	110 x 8	1
50	SNL 511	1211K	-	H211	TSU 511	TSNG 511	ASNH 511	100 x 11,5	2
	SNL 511	2211K	22211K	H311	TSU 511	TSNG 511	ASNH 511	100 x 9,5	2
	SNL 513	1311K	21311K	H311	-	TSNG 611	ASNH 513	120 x 11	2
	SNL 513	2311K	22311K	H2311	-	TSNG 611	ASNH 513	120 x 8	1
55	SNL 512	1212K	-	H212	TSU 512	TSNG 512	ASNH 512	110 x 13	2
	SNL 512	2212K	22212K	H312	TSU 512	TSNG 512	ASNH 512	110 x 10	2
	SNL 515	1312K	21312K	H312	-	TSNG 612	ASNH 515	130 x 12,5	2
	SNL 515	2312K	22312K	H2312	-	TSNG 612	ASNH 515	130 x 10	1
60	SNL 513	1213K	-	H213	TSU 513	TSNG 513	ASNH 513	120 x 14	2
	SNL 513	2213K	22213K	H313	TSU 513	TSNG 513	ASNH 513	120 x 10	2
	SNL 516	1313K	21313K	H313	-	TSNG 613	ASNH 516	140 x 12,5	2
	SNL 516	2313K	22313K	H2313	-	TSNG 613	ASNH 516	140 x 10	1
65	SNL 515	1215K	-	H215	TSU 515	TSNG 515	ASNH 513	130 x 15,5	2
	SNL 515	2215K	22215K	H315	TSU 515	TSNG 515	ASNH 513	130 x 12,5	2
	SNL 518	1315K	21315K	H315	-	TSNG 615	ASNH 518	160 x 14	2
	SNL 518	2315K	22315K	H2315	-	TSNG 615	ASNH 518	160 x 10	1
70	SNK 516	1216K	-	H217	TSU 516	TSNG 516	ASNH 516	140 x 16	2
	SNK 516	2216K	22216K	H316	TSU 516	TSNG 516	ASNH 516	140 x 12,5	2
75	SNL 517	1217K	-	H217	TSU 517	TSNG 517	ASNH 517	150 x 16,5	2
	SNL 517	2217K	22217K	H317	TSU 517	TSNG 517	ASNH 517	150 x 12,5	2
	SNL 520	1317K	21317K	H317	-	TSNG 617	ASNH 520	180 x 14,5	2
	SNL 520	2317K	22317K	H2317	-	TSNG 617	ASNH 520	180 x 10	1
80	SNL 518	1218K	-	H218	TSU 518	TSNG 518	ASNH 518	160 x 17,5	2
	SNL 518	2218K	22218K	H318	TSU 518	TSNG 518	ASNH 518	160 x 12,5	2
	SNL 518	-	23218K	H2318	TSU 518	TSNG 518	ASNH 518	160 x 12,5	1
85	SNL 522	-	22319K	H2319	-	TSNG 619	ASNH 522	200 x 13	1
90	SNL 520	1220K	-	H220	TSU 520	TSNG 520	ASNH 520	180 x 18	2
	SNL 520	2220K	22220K	H320	TSU 520	TSNG 520	ASNH 520	180 x 12	2
	SNL 520	-	23220K	H2320	TSU 520	TSNG 520	ASNH 520	180 x 9,7	1
	SNL 524	-	22320K	H2320	-	TSNG 620	ASNH 524	215 x 13	1
100	SNL 522	1222K	-	H222	TSU 522	TSNG 522	ASNH 522	200 x 21	2
	SNL 522	2222K	22222K	H322	TSU 522	TSNG 522	ASNH 522	200 x 13,5	2
	SNL 522	-	23222K	H2322	TSU 522	TSNG 522	ASNH 522	200 x 10,2	1
110	SNL 524	-	22224K	H3124	TSU 524	TSNG 524	ASNH 524	215 x 14	2
	SNL 524	-	23224K	H2324	TSU 524	TSNG 524	ASNH 524	215 x 10	1

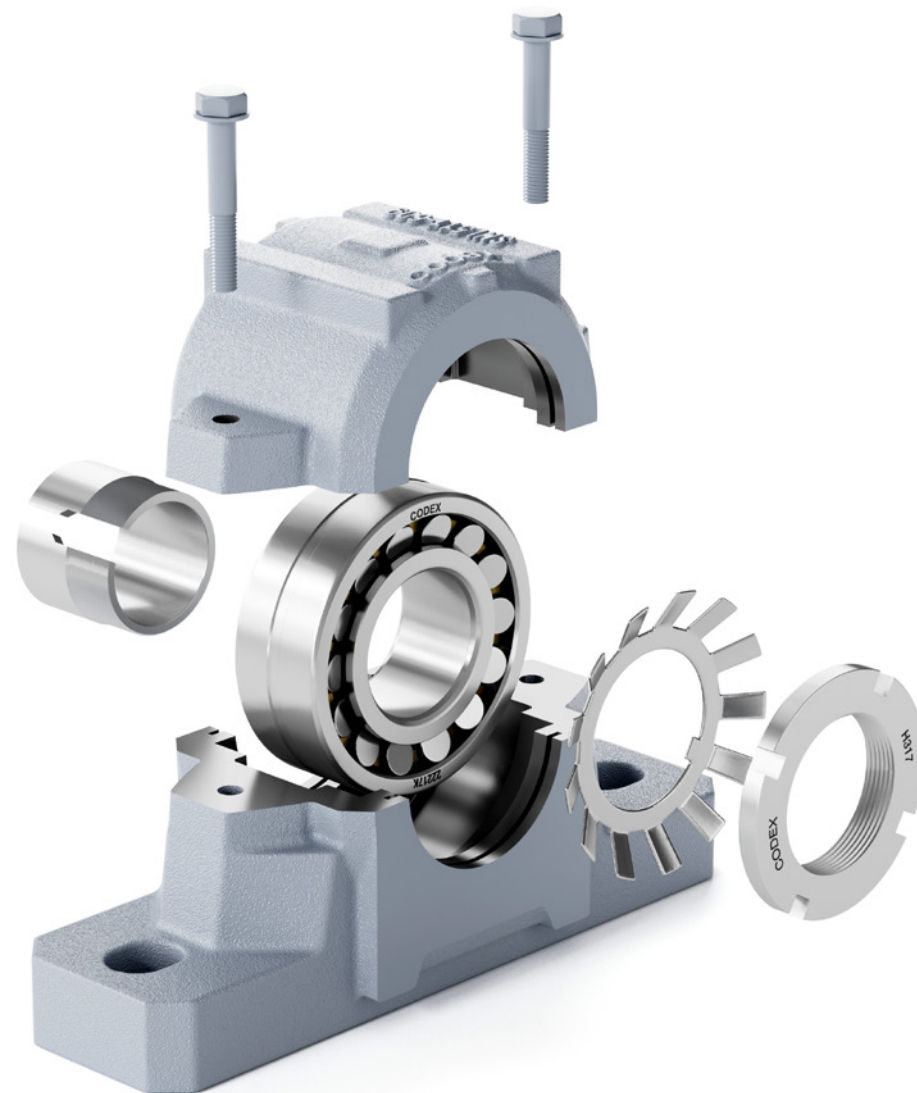

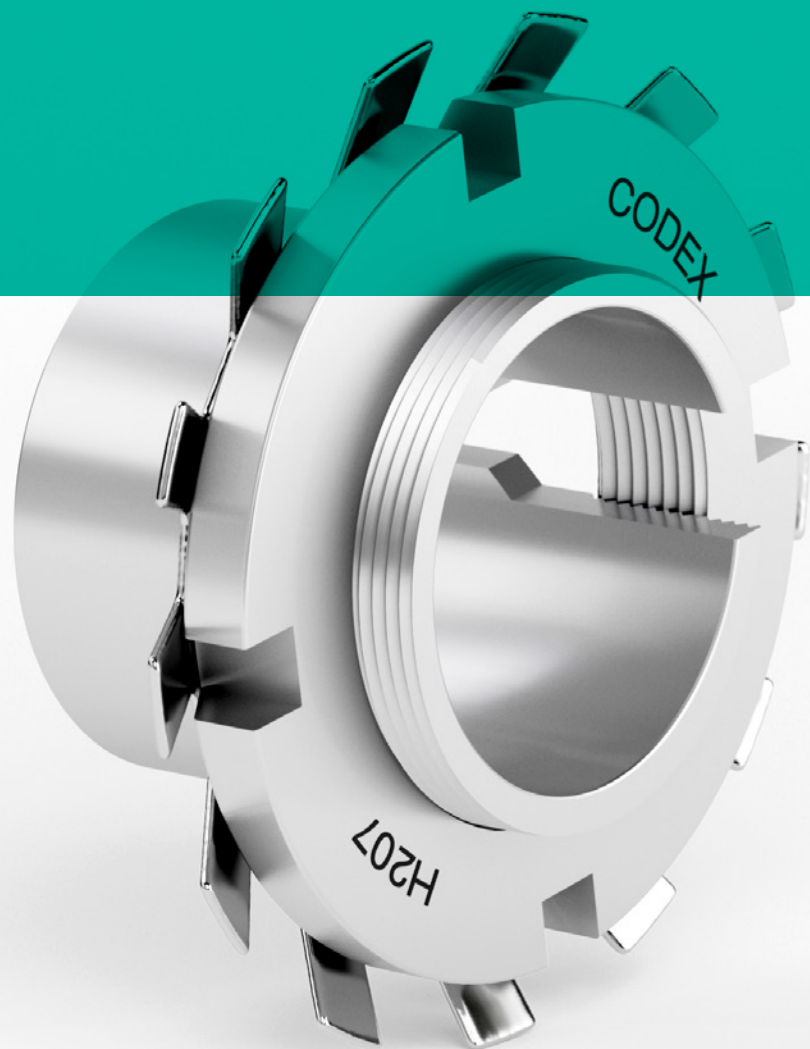

Bearing accessories

ADAPTER SLEEVES

H2 (HE, HS, HA)

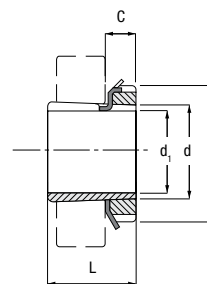

	d	d1	L	D	C	AN/KMAW/MB	Weight (kg)
H 204	20	17	24	32	7	4	0,041
H 205	25	20	26	38	8	5	0,07
H 206	30	25	27	45	8	6	0,099
H 207	35	30	29	52	9	7	0,125
H 208	40	35	31	58	10	8	0,174
H 209	45	40	33	65	11	9	0,227
H 210	50	45	35	70	12	10	0,274
H 211	55	50	37	75	12	11	0,308
H 212	60	55	38	80	13	12	0,346
H 213	65	60	40	85	14	13	0,401
H 214	70	65	41	92	14	14	0,593
H 215	75	70	43	98	15	15	0,707
H 216	80	75	46	105	17	16	0,882
H 217	85	80	50	110	18	17	1,02
H 218	90	85	52	120	18	18	1,19
H 219	95	90	55	125	19	19	1,37
H 220	100	95	58	130	20	20	1,49
H 221	105	100	60	140	20	21	1,72
H 222	110	105	63	145	21	22	1,93

H3 (HE, HS, HA)

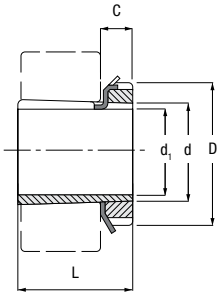

	d	d1	L	D	C	AN/KMAW/MB	Weight (kg)
H304	20	17	28	32	7	4	0,045
H305	25	20	29	38	8	5	0,075
H306	30	25	31	45	8	6	0,109
H307	35	30	35	52	9	7	0,142
H308	40	35	36	58	10	8	0,189
H309	45	40	39	65	11	9	0,248
H310	50	45	42	70	12	10	0,303
H311	55	50	45	75	12	11	0,345
H312	60	55	47	80	13	12	0,394
H313	65	60	50	85	14	13	0,458
H314	70	65	52	92	14	14	0,723
H315	75	70	55	98	15	15	0,831
H316	80	75	59	105	17	16	1,03
H317	85	80	63	110	18	17	1,18
H318	90	85	65	120	18	18	1,37
H319	95	90	68	125	19	19	1,56
H320	100	95	71	130	20	20	1,69
H321	105	100	74	140	20	21	1,95
H322	110	105	77	145	21	22	2,18

H23 (HE, HS, HA)

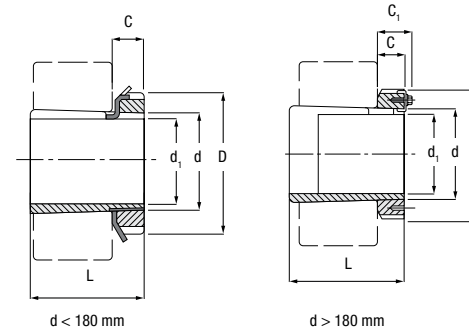

	d	d1	L	D	C	C1	AN/KM AW/MB
H 2304	20	17	31	32	7	-	4
H 2305	25	20	35	38	8	-	5
H 2306	30	25	38	45	8	-	6
H 2307	35	30	43	52	9	-	7
H 2308	40	35	46	58	10	-	8
H 2309	45	40	50	65	11	-	9
H 2310	50	45	55	70	12	-	10
H 2311	55	50	59	75	12	-	11
H 2312	60	55	62	80	13	-	12
H 2313	65	60	65	85	14	-	13
H 2314	70	60	68	92	14	-	14
H 2315	75	65	73	98	15	-	15
H 2316	80	70	78	105	17	-	16
H 2317	85	75	82	110	18	-	17
H 2318	90	80	86	120	18	-	18
H 2319	95	85	90	125	19	-	19
H 2320	100	90	97	130	20	-	20
H 2321	105	95	101	140	20	-	21
H 2322	110	100	105	145	21	-	22
H 2324	120	110	112	155	22	-	24
H 2326	130	115	121	165	23	-	26
H 2328	140	125	131	180	24	-	28
H 2330	150	135	139	195	26	-	30
H 2332	160	140	147	210	28	-	32
H 2334	170	150	154	220	29	-	34
H 2336	180	160	161	230	30	-	36
H 2338	190	170	169	240	31	-	38
H 2340	200	180	176	250	32	-	40
H 2344	220	200	186	280	35	44	44
H 2348	240	220	199	300	37	46	48
H 2352	260	240	211	330	39	49	52
H2356	280	260	224	350	41	51	56
AN/KM32	M 160X3	210	25	182	16	7	2,59

H30, H31 (HE)

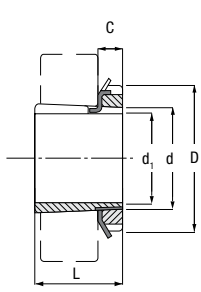

d < 180 mm

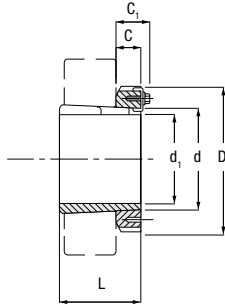

d > 180 mm

	d	d1	L	D	C	Weight (kg)
H 3024	120	110	72	145	22	1,93
H 3026	130	115	80	155	23	2,85
H 3028	140	125	82	165	24	3,16
H 3030	150	135	87	180	26	3,89
H 3032	160	140	93	190	28	5,21
H 3034	170	150	101	200	29	5,99
H 3036	180	160	109	210	30	6,83
H 3038	190	170	112	220	31	7,45
H 3040	200	180	120	240	32	9,19
H 3120	100	90	76	130	20	1,8
H 3122	110	100	81	145	21	2,25
H 3124	120	110	88	155	22	2,64
H 3126	130	115	92	165	23	3,66
H 3128	140	125	97	180	24	4,34
H 3130	150	135	111	195	26	5,52
H 3132	160	140	119	210	28	7,67
H 3134	170	150	122	220	29	8,38
H 3136	180	160	131	230	30	9,5
H 3138	190	170	141	240	31	10,8
H 3140	200	180	150	250	32	12,1

AN / KM

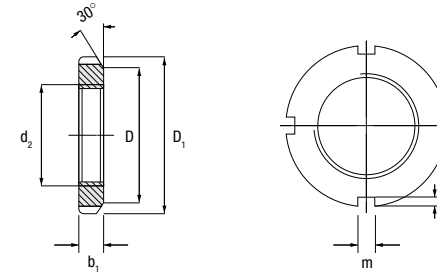

	d2	D1	b1	D	m	n	Weight (kg)
AN/KM0	M 10X0,75	18	4	13	3	2	0,004
AN/KM1	M 12X1	22	4	17	3	2	0,007
AN/KM2	M 15X1	25	5	21	4	2	0,01
AN/KM3	M 17X1	28	5	24	4	2	0,013
AN/KM4	M 20X1	32	6	26	4	2	0,019
AN/KM5	M 25X1,5	38	7	32	5	2	0,025
AN/KM6	M 30X1,5	45	7	38	5	2	0,043
AN/KM7	M 35X1,5	52	8	44	5	2	0,053
AN/KM8	M 40X1,5	58	9	50	6	2,5	0,085
AN/KM9	M 45X1,5	65	10	56	6	2,5	0,119
AN/KM10	M 50X1,5	70	11	61	6	2,5	0,148
AN/KM11	M 55X2	75	11	67	7	3	0,158
AN/KM12	M 60X2	80	11	73	7	3	0,174
AN/KM13	M 65X2	85	12	79	7	3	0,203
AN/KM14	M70X2	95	12	85	8	3,5	0,242
AN/KM15	M 75X2	96	13	90	8	3,5	0,287
AN/KM16	M 80X2	105	15	95	8	3,5	0,397
AN/KM17	M 85X2	110	16	102	8	3,5	0,451
AN/KM18	M 90X2	120	16	108	10	4	0,556
AN/KM19	M 95X2	125	17	113	10	4	0,658
AN/KM20	M 100X2	130	18	120	10	4	0,698
AN/KM21	M 105X2	140	18	126	12	5	0,845
AN/KM22	M 110X2	145	19	133	12	5	0,965
AN/KM23	M 115X2	150	19	137	12	5	1,01
AN/KM24	M 120X2	155	20	138	12	5	1,08
AN/KM25	M 125X2	160	21	148	12	5	1,19
AN/KM26	M 130X2	165	21	149	12	5	1,25
AN/KM27	M 135X2	175	22	160	14	6	1,55
AN/KM28	M 140X2	180	22	160	14	6	1,56
AN/KM29	M 145X2	190	24	171	14	6	1,8
AN/KM30	M 150X2	195	24	72	14	6	2,03
AN/KM31	M 155X3	200	25	182	16	7	2,3

	d2	D1	b1	D	m	n	Weight (kg)
AN/KM33	M 165X3	210	26	193	16	7	2,7
AN/KM34	M 170X3	220	26	193	16	7	2,8
AN/KM36	M 180X3	230	27	203	18	8	3,07
AN/KM38	M 190X3	240	28	214	18	8	3,39
AN/KM40	M 200X3	250	29	226	18	8	3,69

AW / MB

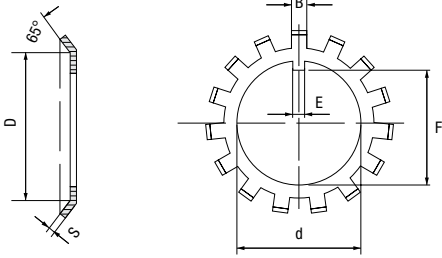

	d	D	S	E	F	B	Weight (100/kg)
AW/MB22	110	133	1,75	12	105,5	12	9,4
AW/MB23	115	137	2	12	110,5	12	10,8
AW/MB24	120	138	2	14	115	12	10,5
AW/MB25	125	148	2	14	120	12	11,8
AW/MB26	130	149	2	14	125	12	11,3
AW/MB27	135	160	2	14	130	14	14,4
AW/MB28	140	160	2	16	135	14	14,2
AW/MB29	145	172	2	16	140	14	16,8
AW/MB30	150	171	2	16	145	14	15,5
AW/MB31	155	182	2,5	16	147,5	16	20,9
AW/MB32	160	182	2,5	18	154	16	22,2
AW/MB33	165	193	2,5	18	157,5	16	24,1
AW/MB34	170	193	2,5	18	164	16	24,7
AW/MB36	180	203	2,5	20	174	18	26,8
AW/MB38	190	214	2,5	20	184	18	27,8
AW/MB40	200	226	2,5	20	194	18	29,3

	d	D	S	E	F	B	Weight (100/kg)
AW/MB0	10	13	1	3	8,5	3	0,131
AW/MB1	12	17	1	3	10,5	3	0,192
AW/MB2	15	21	1	4	13,5	4	0,253
AW/MB3	17	24	1	4	15,5	4	0,313
AW/MB4	20	26	1	4	18,5	4	0,35
AW/MB5	25	32	1,25	5	23	5	0,64
AW/MB6	30	38	1,25	5	27,5	5	0,78
AW/MB7	35	44	1,25	6	32,5	5	1,04
AW/MB8	40	50	1,25	6	37,5	6	1,23
AW/MB9	45	56	1,25	6	42,5	6	1,52
AW/MB10	50	61	1,25	6	47,5	6	1,6
AW/MB11	55	67	1,25	8	52,5	7	1,96
AW/MB12	60	73	1,5	8	57,5	7	2,53
AW/MB13	65	79	1,5	8	62,5	7	2,9
AW/MB14	70	85	1,5	8	66,5	8	3,34
AW/MB15	75	90	1,5	8	71,5	8	3,56
AW/MB16	80	95	1,8	10	76,5	8	4,64
AW/MB17	85	102	1,8	10	81,5	8	5,24
AW/MB18	90	108	1,8	10	86,5	10	6,23
AW/MB19	95	113	1,8	10	91,5	10	6,7
AW/MB20	100	120	1,8	12	96,5	10	7,65
AW/MB21	105	126	1,8	12	100,5	12	8,26

Codex Bearing Catalogue

Copyright © Codex d.o.o.
September 2022

Codex d.o.o.
Plese 7b
9000 Murska Sobota
Slovenia

www.codex.si

Codex d.o.o. reserves the right to changes without prior notice.

The latest version of the catalogue can be downloaded from the website www.codex.si.

Codex d.o.o. strived for the data in the catalogue to be as correct and accurate as possible. However, we allow the possibility of typing or printing errors. Codex d.o.o. cannot assume liability for any direct or consequential damages arising from the use of data in the catalogue.

codex

Codex d.o.o.

Plese 7/b
9000 Murska Sobota
Slovenia

T +386 (0)2 534 14 60
E info@codex.si

www.codex.si

